



Current Sensing Resistor

RLT0816-3 Series Current Sensing Resistor (Lead / Halogen Free)

Reversion History :

Date	Revision	Changes
2012/08/13	A0	New Approval
2019/09/25	A1	New Approval Standard
2023/09/21	A2	L&W tolerance 0.15mm→0.10mm

RLT0816-3 Series Current Sensing Resistor (Lead / Halogen Free)

Features / Applications :

- High power rating is up to 1/4W
- RoHS compliant
- Suitable for reflow soldering

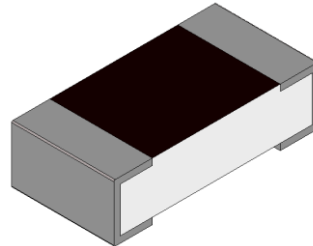

Electrical Specifications :

Characteristics	Feature	
Power Rating*	1/4 W	
Resistance Range	0.05Ω ~ <0.1Ω	0.1Ω ~ <10Ω
Temperature Coefficient of Resistance(ppm/°C)	±300	±200
Resistance Tolerance	±1%(F), ±2%(G), ±5%(J)	
Operation Temperature Range	-55°C ~ +125°C	

***Note :**

Power Rating is based on continuous full load operation at rated ambient temperature of 70°C.

For resistor operated at ambient temperature in excess of 70°C, the maximum load shall be derated in accordance with the following curve.

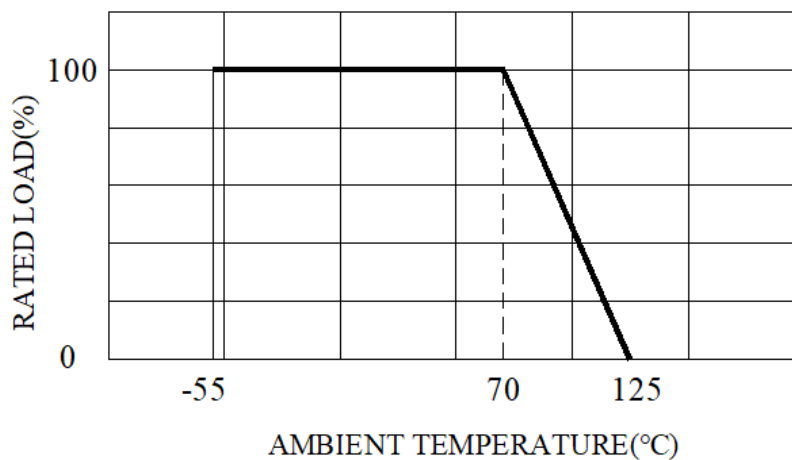

Outline Drawing :

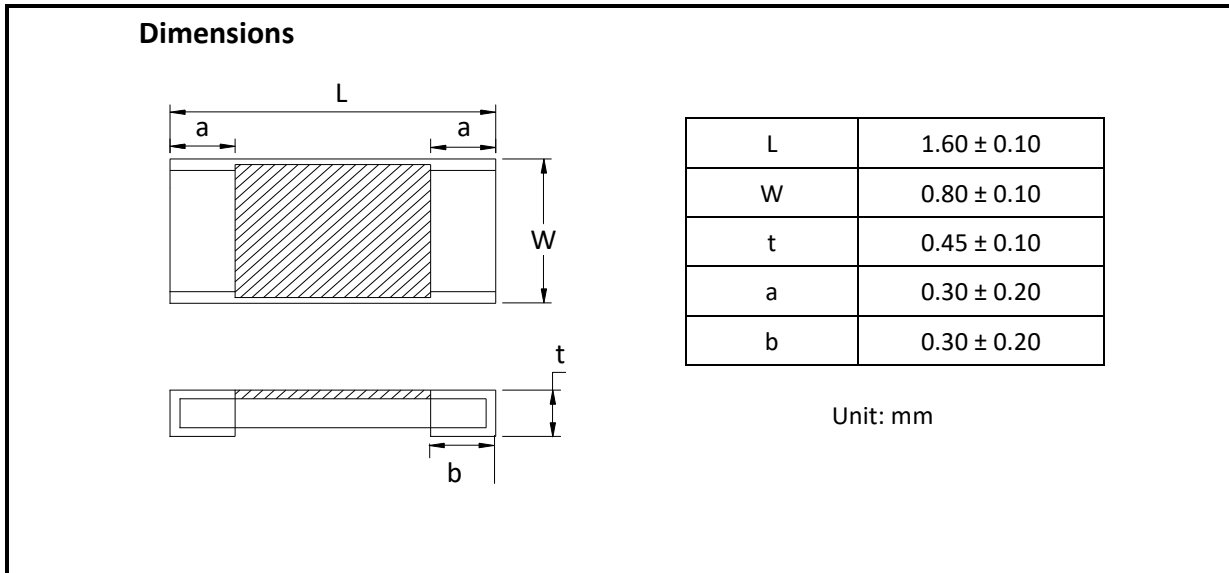

Type Designation :

RLT0816 - 3 - □□□□ - □ NH
 (1) (2) (3) (4) (5)

Note:

- (1) Series No.
- (2) Power Rating: 3 = 1/4W
- (3) Resistance value:
 The "R" shall be used as a decimal point, For example --
 R100 = 0.1Ω; 1R00 = 1.0Ω;
- (4) Tolerance (%): F=±1%, G=±2%, J=±5%
- (5) NH= Sn plating (Lead free / Halogen free)

Characteristics :

Electrical

Item	Specification and Requirement	Test Method (JIS 5201)
Temperature Coefficient of Resistance(ppm/°C)	As electrical specifications	Room temperature Room temperature +100°C
Short Time Overload	$\Delta R: \pm 1.0\%$ Without damage by flashover, spark, arcing, burning or breakdown	2.5 x rated voltage for 5 seconds
Insulation Resistance	Over 100 M Ω on Overcoat layer face up Over 1,000 M Ω on Substrate side face up	(1) Setup as figure 1 (2) Test voltage: 100VDC \pm 15VDC (3) Test time: 60 + 10 / - 0 seconds
Voltage Proof	Resistance range: $\pm 1.0\%$ Without damage by flashover, spark, arcing, burning or breakdown	(1) Setup as figure 1 (2) Test voltage: 100VAC(rms.) (3) Test time: 60 + 10 / - 0 seconds

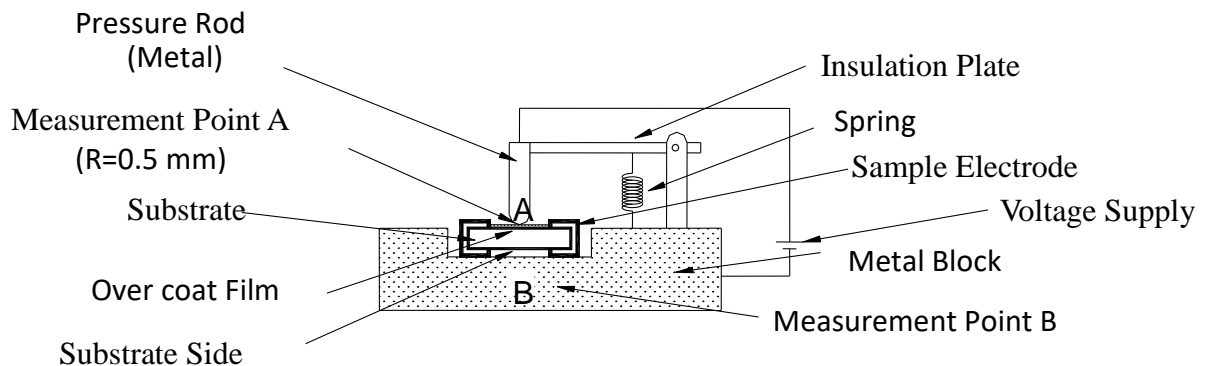

Figure 1 : Measurement Setup

Mechanical

Item	Specification and Requirement	Test Method (JIS 5201)
Solderability	The surface of terminal immersed shall be minimum of 95% covered with a new coating of solder	Solder bath: After immersing in flux, dip in 245 \pm 5°C molten solder bath for 2 \pm 0.5 seconds

Item	Specification and Requirement	Test Method (JIS 5201)
Resistance to Solder Heat	$\Delta R: \pm 1.0\%$ Without distinct deformation in appearance	(1) Pre-heat: 100~110°C for 30 seconds (2) Immersed at solder bath of 270 ± 5°C for 10 ± 1 seconds
Bending Test	$\Delta R: \pm 1.0\%$ Without mechanical damage such as break	Bending value: 3 mm for 30 ± 1 seconds
Solvent Resistance	Without mechanical and distinct damage in appearance	(1) Solvent: Trichloroethane or Isopropyl alcohol (2) Immersed in solvent at room temperature for 300 seconds

Endurance

Item	Specification and Requirement	Test Method (JIS 5201)
Rapid Change of Temperature	$\Delta R: \pm 1.0\%$ Without distinct damage in appearance	-55 ~125°C 5 cycles, 15 min at each extreme condition
Moisture with Load	$\Delta R: \pm 5.0\%$ Without distinct damage in appearance	40 ± 2°C with relative humidity 90% to 95%. D.C. rated voltage for 1.5 hours ON and 0.5 hours OFF. Cycle repeated 1,000 hours
Load Life	$\Delta R: \pm 5.0\%$ Without distinct damage in appearance	Rated voltage for 1.5 hours followed by a pause 0.5 hour at 70 ± 3°C. Cycle repeated 1000 hours
Low Temperature Store	$\Delta R: \pm 5.0\%$ Without distinct damage in appearance	Store temperature: -55 ± 3°C for total 1,000 hours
High Temperature Store	$\Delta R: \pm 5.0\%$ Without distinct damage in appearance	Store temperature: 125 ± 2°C for total 1,000 hours

Recommend Land Pattern Dimensions :

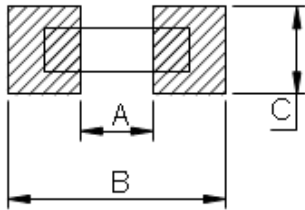

A	0.8~1.0
B	2.4~2.6
C	1.0~1.2

Unit : mm

Notice: We recommend there is no circuit design between pads to avoid circuit short.

Packaging :

Tape packaging dimensions

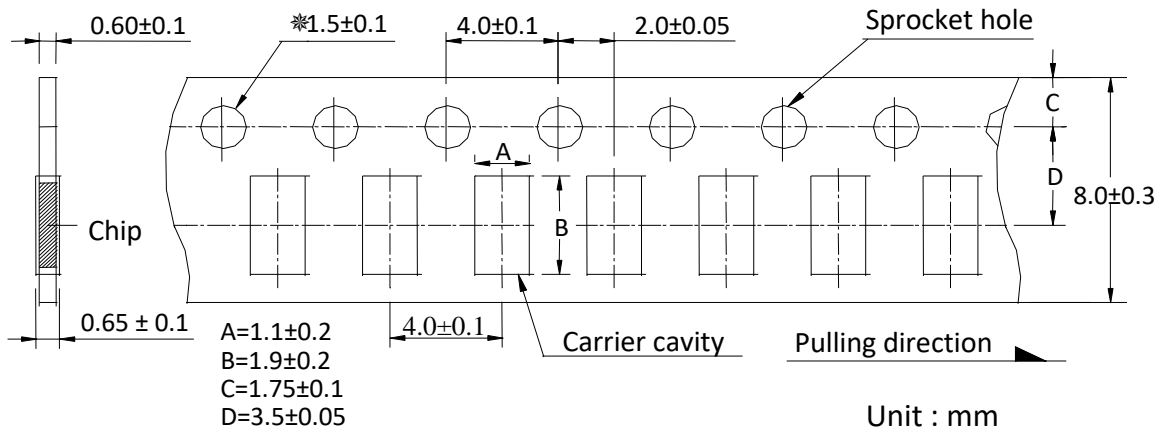

Remark: Leader tape length \geq 30 cm (150 Hollow carrier cavity)

Reel dimensions

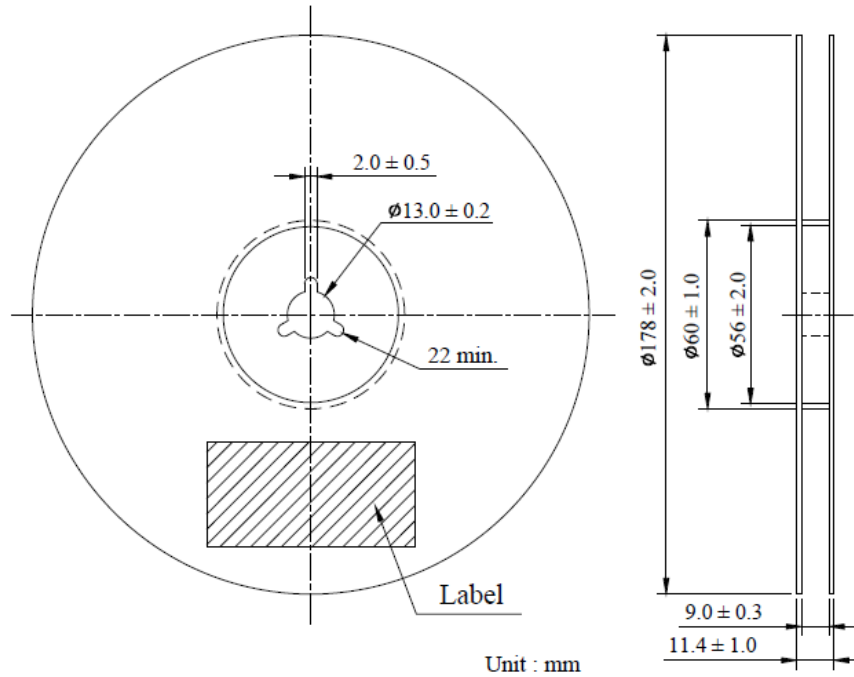

Numbers of Taping : 5,000 pieces /reel

The following items shall be marked on the reel.

- (1) Type designation.
- (2) Quantity
- (3) Manufacturing date code
- (4) Manufacturer's name

Peel force of top cover tape

The peel speed shall be about 300 mm/min. The peel force of top cover tape shall be between 0.1 to 0.7 N.

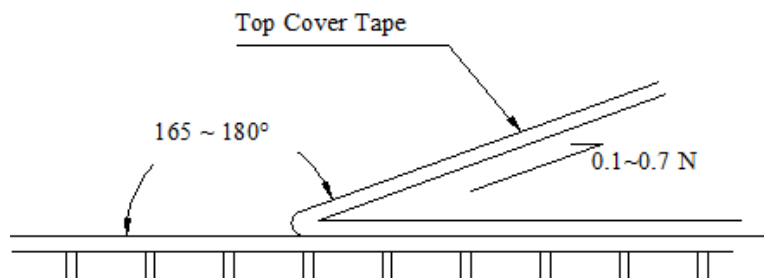

Care Note :

Care note for storage

- (1) Chip resistor shall be stored in a room where temperature and humidity must be controlled.
(temperature 5 to 35°C, humidity 45 to 85% RH) However, a humidity keep it low, as it is possible.
- (2) Chip resistor shall be stored as direct sunshine doesn't hit on it.
- (3) Chip resistor shall be stored with no moisture, dust, a material that will make solderability inferior, and a harmful gas (Chloridation hydrogen, sulfurous acid gas, and sulfuration hydrogen).

Care note for operating and handling

- (1) It is necessary to protect the edge and protection coat of resistors from mechanical stress.
- (2) Handle with care when printing circuit board (PCB) is divided or fixed on support body, because bending of printing circuit board (PCB) mounting will make mechanical stress for resistors.
- (3) Resistors shall be used with in rated range shown in specification. Especially, if voltage more than specified value will be loaded to resistor, there is a case it will make damage for machine because of temperature rise depending on generating of heat, and increase resistance value or breaks.
- (4) In case that resistor is loaded a rated voltage, it is necessary to confirms temperature of a resistor and to reduce a load power according to load reduction curve, because a temperature rise of a resistor depends on influence of heat from mounting density and neighboring element.
- (5) Observe Limiting element voltage and maximum overload voltage specified in each specification
- (6) If there is possibility that a large voltage (pulse voltage, shock voltage) charge to resistor, it is necessary that operating condition shall be set up before use.