

ELECTRICAL SPECIFICATION:

Parameters	Symbol	Value	Note
Input Voltage	VIN	6V~16.0V	Note 1
Output Voltage	VOUT	Adjust	
Maximum Operation Output Current	IOUT	10A	0.6V~2.5V
		8A	3.3V~5.5V
Enable Voltage	EN	1.22V~Vin	Note 2

Note 1. The input voltage of the EVB can range from 6V to 16V. The minimum 6V input voltage is limited by the EN signal, which is derived from VIN through a resistor divider (R1 and R2).

Lower input voltage (as low as 4.5V) please remove R2 (R1 must above 499KΩ while Vin maximum to 16V).

Note 2. Need to Remove R1 and R2 when use external signal to control on/off of module

PROGRAMMING OUTPUT VOLTAGE:

$$V_{OUT} = 0.6 \times \left(1 + \frac{R_{FBH}}{R_{FBL}} \right) \quad (EQ.1)$$

Assume RFBH set 976 ohm, The output voltage can be calculated as shown in Equation 1, and the resistance (R8~R12) according to typical output voltage is shown in TABLE 1.

Vout	1V	1.2V	1.8V	3.3V	5V
RFBL (Ohm)	1.47k	976	487	215	133

TABLE 1: OUTPUT VOLTAGE SETTING

PROGRAMMING OVER CURRENT LIMIT:

In maximum Output Current condition, recommended Rcs (R7) as Table 2.

Vout	0.6V~2.5V	3.3~5.5V
RCS (Ω)	4.87K	5.6K

TABLE 2: OCP SETTING

PROGRAMMING SOFT START TIME:

The minimum soft-start time is limited at 1ms. It can be increased by adding a SS capacitor (C10) between TRK and Vosns-. The total SS capacitor value can be determined with Equation (2):

$$C_{SS}(nF) = \frac{T_{SS}(ms) \times 36(\mu A)}{0.6(V)} - 22nF \quad (EQ.2)$$

EVALUATION BOARD SCHEMATIC:

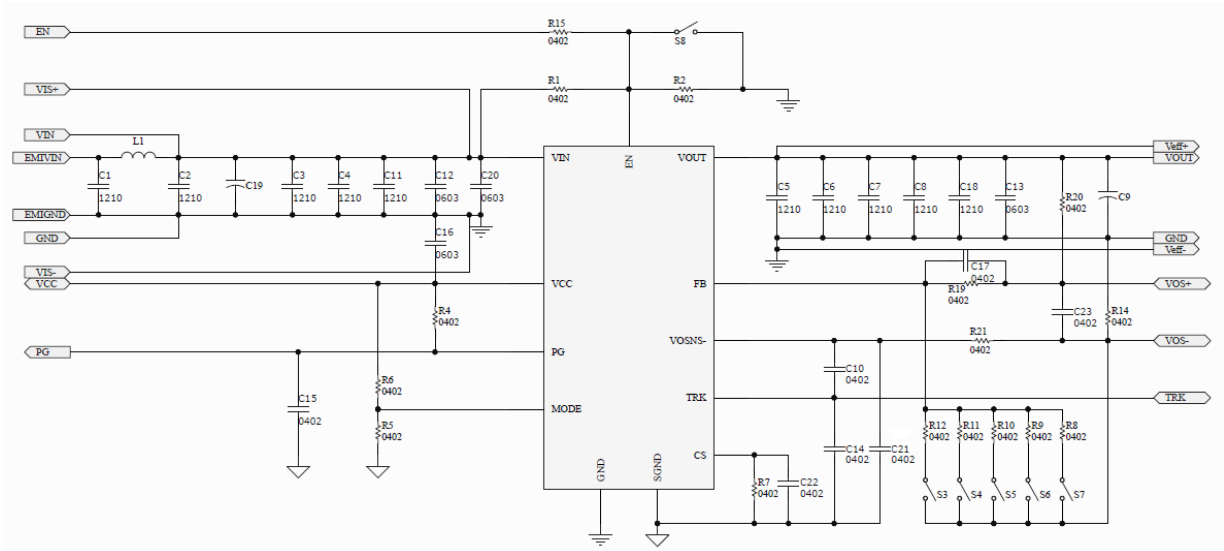

Note. VIS+, VIS-, Veff+, Veff- pin are for efficiency of module measurement

QUICK START GUIDE:

1. VIN and GND connect to power supply and Turn on MSN12AD20-MQ module when S8 open.
2. Short S7~S3 to set output voltage from 1.0V to 5.0V

	S7	S6	S5	S4	S3
Vout	1V	1.2V	1.8V	3.3V	5V

3. Short S8 to turn off Power module.

QUICK START GUIDE (cont.):

TOP VIEW

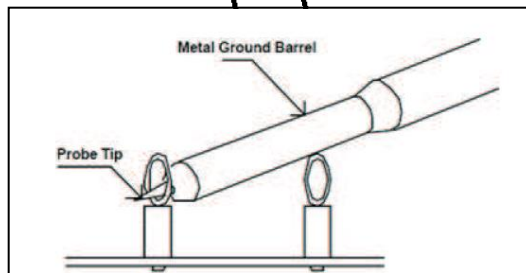
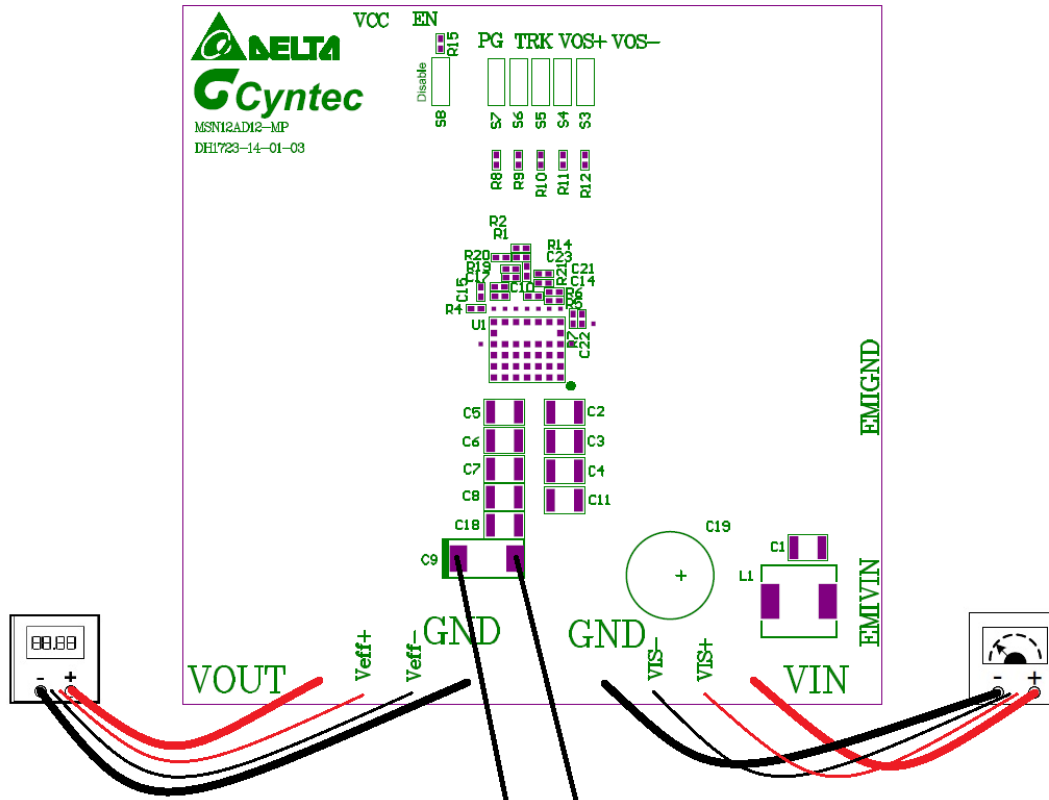

BOTTOM VIEW

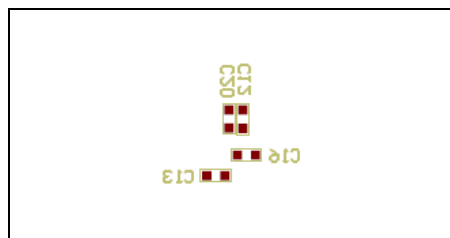

PRINTED CIRCUIT BOARD LAYOUT:

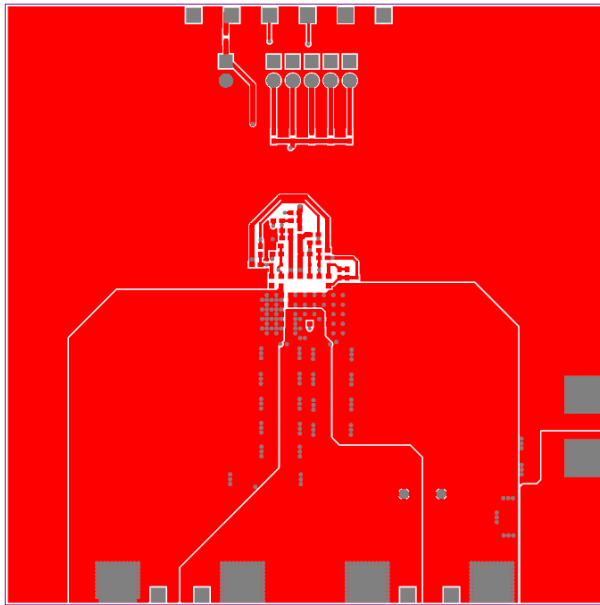

Top Layer

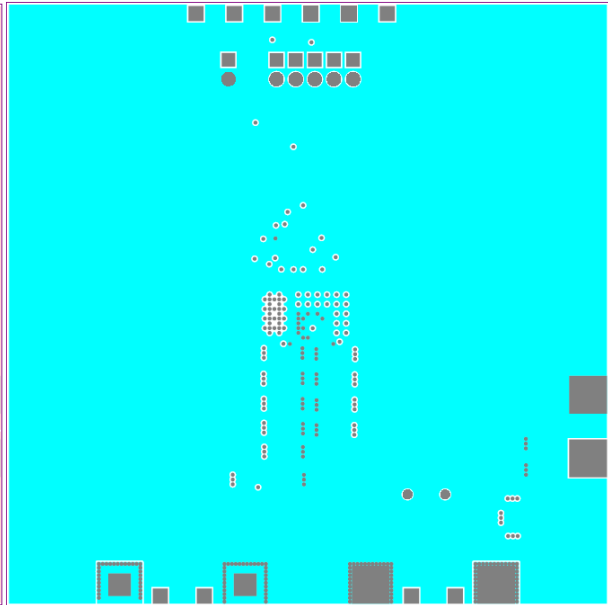

Mid 1 Layer

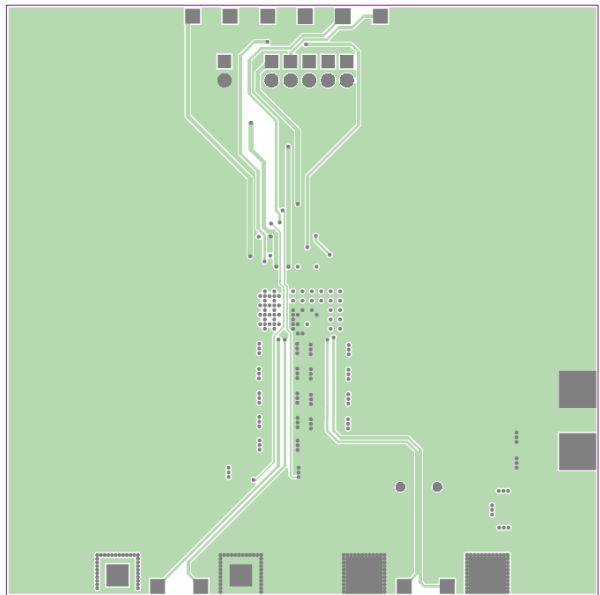

Mid 2 Layer

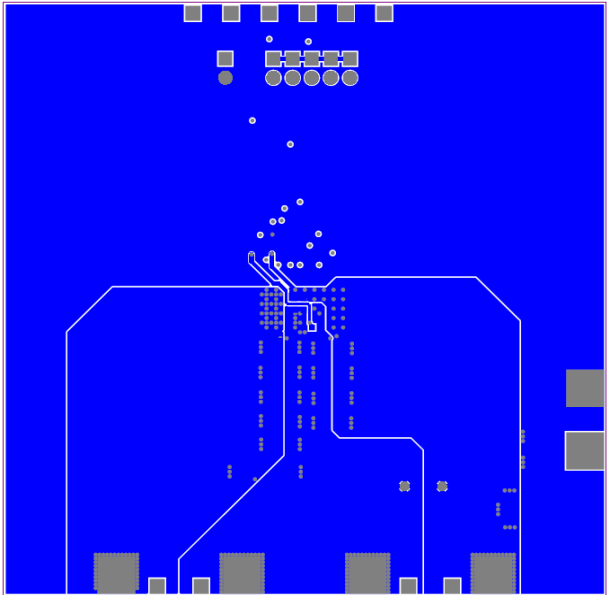

Bottom Layer

BOM LIST:

COUNT	REF DES	DESCRIPTION	PART NUMBER	MFR
0	C1	MLCC, 1210	NA	NA
2	C2, C3	MLCC, 22uF, 25V, X7R, 1210	Std	Std
0	C4, C11	MLCC, 22uF, 25V, X7R, 1210	NA	NA
3	C5, C6, C7	MLCC, 47uF, 10V, X7R, 1210	Std	Std
0	C8, C18	MLCC, 47uF, 10V, X7R, 1210	NA	NA
0	C9	POSCAP, 330uF, 6.3V, Code D3L	6TPE330MIL	Panasonic
1	C10	MLCC, 0.1uF,10V, X7R, 0402	Std	Std
1	C12	MLCC, 1uF,25V, X7R, 0603	Std	Std
0	C13, C16	MLCC, 0603	NA	NA
0	C14	MLCC, 0402	NA	NA
1	C15	MLCC, 10nF, 16V, X7R, 0402	Std	Std
1	C17	MLCC, 3.3nF, 50V, X7R, 0402	Std	Std
0	C19	NA	NA	NA
1	C20	MLCC, 100pF, 50V, C0G, 0402	Std	Std
1	C21	MLCC, 22pF, 50V, C0G, 0402	Std	Std
1	C22	MLCC, 47pF, 50V, C0G, 0402	Std	Std
1	C23	MLCC, 15pF, 50V, C0G, 0402	Std	Std
2	R1, R15	Resistor, 499kOhm, $\pm 1\%$, 0402	Std	Std
1	R2	Resistor, 140kOhm, $\pm 1\%$, 0402	Std	Std
1	R4	Resistor, 10kOhm, $\pm 1\%$, 0402	Std	Std
1	R5	Resistor, 60.4k Ohm, $\pm 1\%$, 0402	Std	Std
0	R6	Resistor, 0402	NA	NA
1	R7	Resistor, 4.87k Ohm, $\pm 1\%$, 0402 (for output current 10A operation)	Std	Std
0	R7	Resistor, 5.6k Ohm, $\pm 1\%$, 0402 (for output current 8A operation)	Std	Std
1	R8	Resistor, 1.47k Ohm, $\pm 1\%$, 0402	Std	Std
1	R9	Resistor, 976 Ohm, $\pm 1\%$, 0402	Std	Std
1	R10	Resistor, 487 Ohm, $\pm 1\%$, 0402	Std	Std
1	R11	Resistor, 215 Ohm, $\pm 1\%$, 0402	Std	Std
1	R12	Resistor, 133 Ohm, $\pm 1\%$, 0402	Std	Std
2	R14, R20	Resistor, 0 Ohm, $\pm 1\%$, 0402	Std	Std
1	R19	Resistor, 976 Ohm, $\pm 1\%$, 0402	Std	Std
1	R21	Resistor, 2 Ohm, $\pm 1\%$, 0402	Std	Std
0	L1	Inductance	NA	NA
6	S3~S8	Jump, pitch 2.54mm	Std	Std
1	U1	Power module, 8.6*7.5*6.5mm	MSN12AD12-MP	Cyntec

REVISION HISTORY:

Date	Revision	Changes
2018.01.02	00	Issue initial preliminary EVB guide.
2018.01.17	01	1 · Remove page 1 Mode select description 2 · Update page 5 BOM list
2018.04.19	02	Update page 5 BOM list
2018.08.03	03	1 · Add typical and MAX. output Current description 2 · Update OCP Setting table 3 · Update EVB schematic 4 · Update BOM list
2018.12.27	04	1 · Update page 2 EVB schematic 2 · Update page 3 quick start guide 3 · Update page 4 Layout 4 · Update page 5 BOM
2019.01.22	05	1 · Update page 2 EVB schematic 2 · Update page 3 quick start guide 3 · Update page 5 BOM
2019.04.03	06	1 · Update page 2 EVB schematic 2 · Update page 3 quick start guide 3 · Update page 4 Layout 4 · Update page 5 BOM
2019.09.05	07	1 · Update page 2 EVB schematic for change C14 and C21 2 · Update Page 5 BOM for 10A and 8A operation