

1.0A, High Efficiency uPOL Module

FEATURES:

- High Density Integration Module
- 1.0A Output Current
- 92% Peak Efficiency at 3.3VIN
- Input Voltage Range from 2.5V to 5.5V
- Output Voltage Range from 0.8V to 4.0V
- Enable Function
- Automatic Power Saving/PWM Mode
- Protections (UVLO, OCP: Non-latching)
- Internal Soft Start
- Compact Size: 2.5mm*2.0mm*1.1mm
- Pb-free for RoHS compliant
- MSL 2, 260°C Reflow

APPLICATIONS:

- Single Li-Ion Battery-Powered Equipment
- LDOs Replacement
- Cell Phones / PDAs / Palmtops

GENERAL DESCRIPTION:

The uPOL module is non-isolated dc-dc converter that can deliver up to 1.0A of output current. The PWM switching regulator, high frequency power inductor, input/output bulk capacitors are integrated in one hybrid package.

The module has automatic operation with PWM mode and power saving mode according to loading. Other features include remote enable function, internal soft-start, non-latching over current protection, short circuit protection and input under voltage locked-out capability.

The low profile and compact size package (2.5mm × 2.0mm × 1.1mm(max)) is suitable for automated assembly by standard surface mount equipment. The module is Pb-free and RoHS compliance.

TYPICAL APPLICATION CIRCUIT & PACKAGE SIZE:

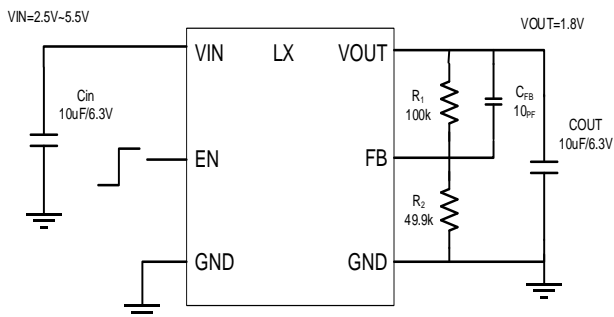

FIG.1 TYPICAL APPLICATION CIRCUIT

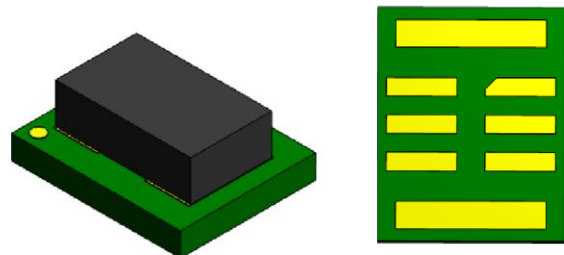

FIG.2 HIGH DENSITY LOW PROFILE

uPOL MODULE

TABLE 1. OUTPUT VOLTAGE SETTING

Vout	1.0V	1.2V	1.5V	1.8V	2.5V	3.3V
RFB_top(Ω)	100k					
RFB_bot(Ω)	150k	100k	66.5k	50k	31.6k	22.1k

ORDER INFORMATION:

Part Number	Ambient Temp. Range (°C)	Package (Pb-Free)	MSL	Note
MUN3CAD01-SB	-40 ~ +85	QFN	Level 2	-

Order Code	Packing	Quantity
MUN3CAD01-SB	Tape and reel	2000

PIN CONFIGURATION:

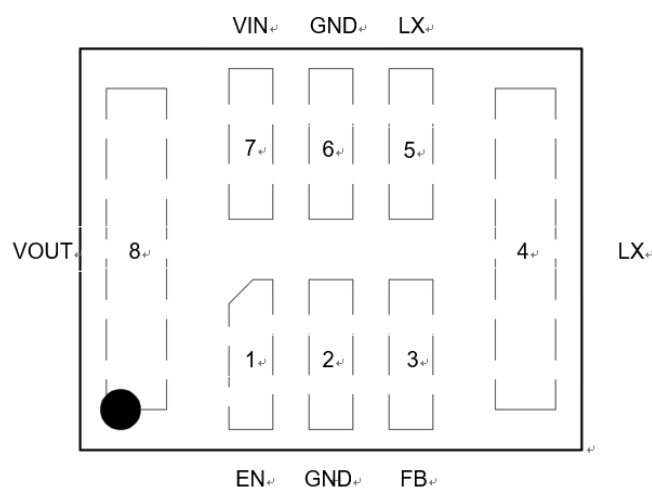

TOP VIEW

PIN DESCRIPTION:

Symbol	Pin No.	Description
EN	1	On/Off control pin for module. EN = LOW, the module is off. EN = HIGH, the module is on. Do not float.
GND	2, 6	Power ground pin for signal, input, and output return path. This pin needs to connect one or more ground plane directly.
FB	3	Feedback input. Connect to output through a voltage dividing resistors for adjusting output voltage. Place those resistors as closely as possible to this pin.
LX	4, 5	Switch output. Connect to thermal exposed pad of LX for heat transferring.
VIN	7	Power input pin. It needs to connect input rail.
VOUT	8	Power output pin. Connect to output for the load.

ELECTRICAL SPECIFICATIONS:

CAUTION: Do not operate at or near absolute maximum rating listed for extended periods of time. This stress may adversely impact product reliability and result in failures not covered by warranty.

Parameter	Description	Min.	Typ.	Max.	Unit
■ Absolute Maximum Ratings					
VIN to GND	Note 1	-	-	+6.0	V
VOUT to GND	Note 1	-	-	+6.0	V
EN to GND	Note 1	-	-	VIN+0.6	V
Tc	Case Temperature of Inductor	-	-	+110	°C
Tj	Junction Temperature	-40	-	+150	°C
Tstg	Storage Temperature	-40	-	+125	°C
ESD Rating	Human Body Model (HBM)	-	-	2k	V
	Machine Model (MM)	-	-	200	V
	Charge Device Model (CDM)	-	-	1k	V
■ Recommendation Operating Ratings					
VIN	Input Supply Voltage	+2.5	-	+5.5	V
VOUT	Output Voltage	+0.8	-	+4.0	V
Ta	Ambient Temperature	-40	-	+85	°C
■ Thermal Information					
Rth(jchoke-a)	Thermal resistance from junction to ambient. (Note 1)	-	54.1	-	°C/W

NOTES:

1. Rth(jchoke-a) is measured with the component mounted on an effective thermal conductivity test board on 0 LFM condition. The test board size is 30mm×30mm×1.6mm with 4 layers, 1oz. The test condition is complied with JEDEC EIJ/JESD 51 Standards.

ELECTRICAL SPECIFICATIONS: (Cont.)

Conditions: $T_A = 25\text{ }^\circ\text{C}$, unless otherwise specified. Test Board Information: 30mm×30mm×1.6mm, 4 layers 20z .

The output ripple and transient response measurement is short loop probing and 20MHz bandwidth limited. $V_{in} = 3.3\text{V}$, $V_{out} = 1.2\text{V}$, unless otherwise specified.

Symbol	Parameter	Conditions	Min.	Typ.	Max.	Unit
■ Input Characteristics						
$I_{SD(IN)}$	Input shutdown current	$V_{in} = 3.3\text{V}$, $EN = GND$	-	0.3	1	μA
$I_{(IN)}$	Input supply current	$V_{in} = 3.3\text{V}$, $I_{out} = 0\text{A}$ $EN = VIN$, $V_{out} = 1.2\text{V}$	-	75	-	μA
$I_{S(IN)}$	Input supply current	$V_{in} = 3.3\text{V}$, $EN = VIN$	-	-	-	-
		$I_{out} = 5\text{mA}$ $V_{out} = 1.2\text{V}$	-	3	-	mA
		$I_{out} = 100\text{mA}$ $V_{out} = 1.2\text{V}$	-	45	-	mA
		$I_{out} = 1000\text{mA}$ $V_{out} = 1.2\text{V}$	-	480	-	mA
■ Output Characteristics						
$I_{OUT(DC)}$	Output continuous current range	$V_{in}=3.3\text{V}$, $V_{out}=1.2\text{V}$	0	-	1000	mA
$V_{O(SET)}$	Output Voltage set Point	With 0.5% tolerance for external resistor used to set output voltage	-2.0	-	+2.0	% $V_{O(SET)}$
$\frac{\Delta V_{OUT}}{\Delta V_{IN}}$	Line regulation accuracy	$V_{in} = 3.3\text{V}$ to 5V $V_{out} = 1.2\text{V}$, $I_{out} = 10\text{mA}$ $V_{out} = 1.2\text{V}$, $I_{out} = 1000\text{mA}$	-	0.1	1	% $V_{O(SET)}$
$\frac{\Delta V_{OUT}}{\Delta I_{OUT}}$	Load regulation accuracy	$I_{out} = 10\text{mA}$ to 1000mA $V_{in} = 3.3\text{V}$, $V_{out} = 1.2\text{V}$	-	0.5	1.5	% $V_{O(SET)}$
$V_{OUT(AC)}$	Output ripple voltage	$V_{in} = 3.3\text{V}$, $V_{out} = 1.2\text{V}$ $EN = VIN$	-	-	-	-
		$I_{OUT} = 5\text{mA}$,	-	30	-	mVp-p
		$I_{OUT} = 1000\text{mA}$,	-	10	-	mVp-p
$C_{OUT(MAX)}$	Maximum capacitive load	$I_{out} = 1000\text{mA}$, $ESR \geq 1\text{ m}\Omega$	-	-	150	μF

ELECTRICAL SPECIFICATIONS: (Cont.)

Conditions: $T_A = 25\text{ }^\circ\text{C}$, unless otherwise specified. Test Board Information: 30mm×30mm×1.6mm, 4 layers 20z .

The output ripple and transient response measurement is short loop probing and 20MHz bandwidth limited. $V_{in} = 3.3\text{V}$, $V_{out} = 1.2\text{V}$, unless otherwise specified.

Symbol	Parameter	Conditions	Min.	Typ.	Max.	Unit
■ Control Characteristics						
V_{REF}	Reference voltage		0.588	0.6	0.612	V
F_{OSC}	Oscillator frequency	PWM Operation	-	3.0	-	MHz
V_{EN_TH}	Enable rising threshold voltage		1.5	-	-	V
	Enable falling threshold voltage		-	-	0.4	V
■ Fault Protection						
V_{UVLO_TH}	Input under voltage lockout threshold	Falling,	-	2.5	-	V
T_{OTP}	Over temp protection		-	160	-	$^\circ\text{C}$
I_{LIMIT_TH}	Current limit threshold	Peak value of inductor current,	1.3	-		A

TYPICAL PERFORMANCE CHARACTERISTICS: (1.0VOUT)

Conditions: $T_A = 25\text{ }^\circ\text{C}$, unless otherwise specified. Test Board Information: 30mm×30mm×1.6mm, 4 layers 20z .

The output ripple and transient response measurement is short loop probing and 20MHz bandwidth limited. The following figures provide the typical characteristic curves at 1.0Vout.

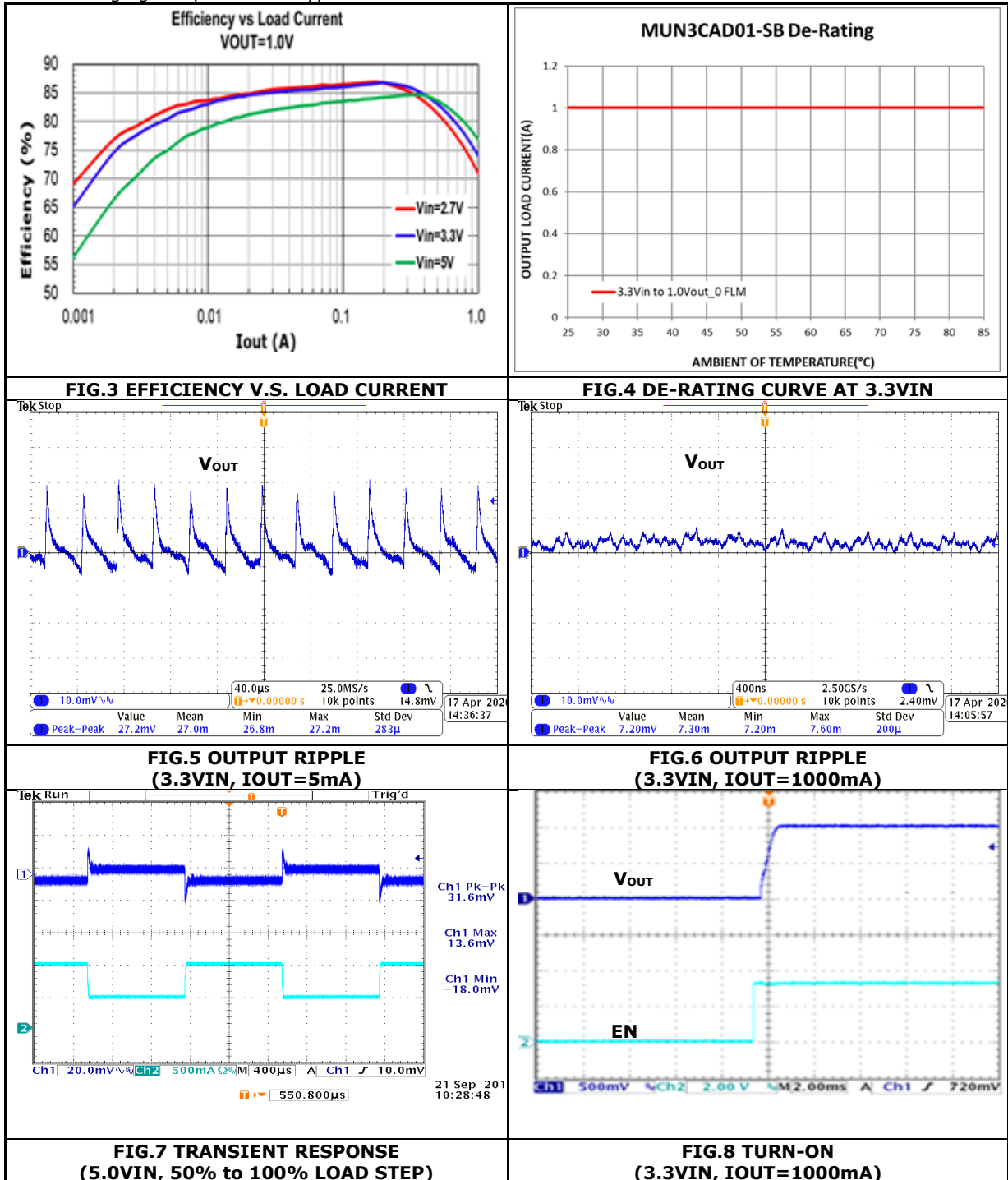

TYPICAL PERFORMANCE CHARACTERISTICS: (1.2VOUT)

Conditions: $T_A = 25^\circ\text{C}$, unless otherwise specified. Test Board Information: 30mm×30mm×1.6mm, 4 layers 2Oz.

The output ripple and transient response measurement is short loop probing and 20MHz bandwidth limited. $V_{in} = 3.3\text{V}$, $V_{out} = 1.2\text{V}$, unless otherwise specified.

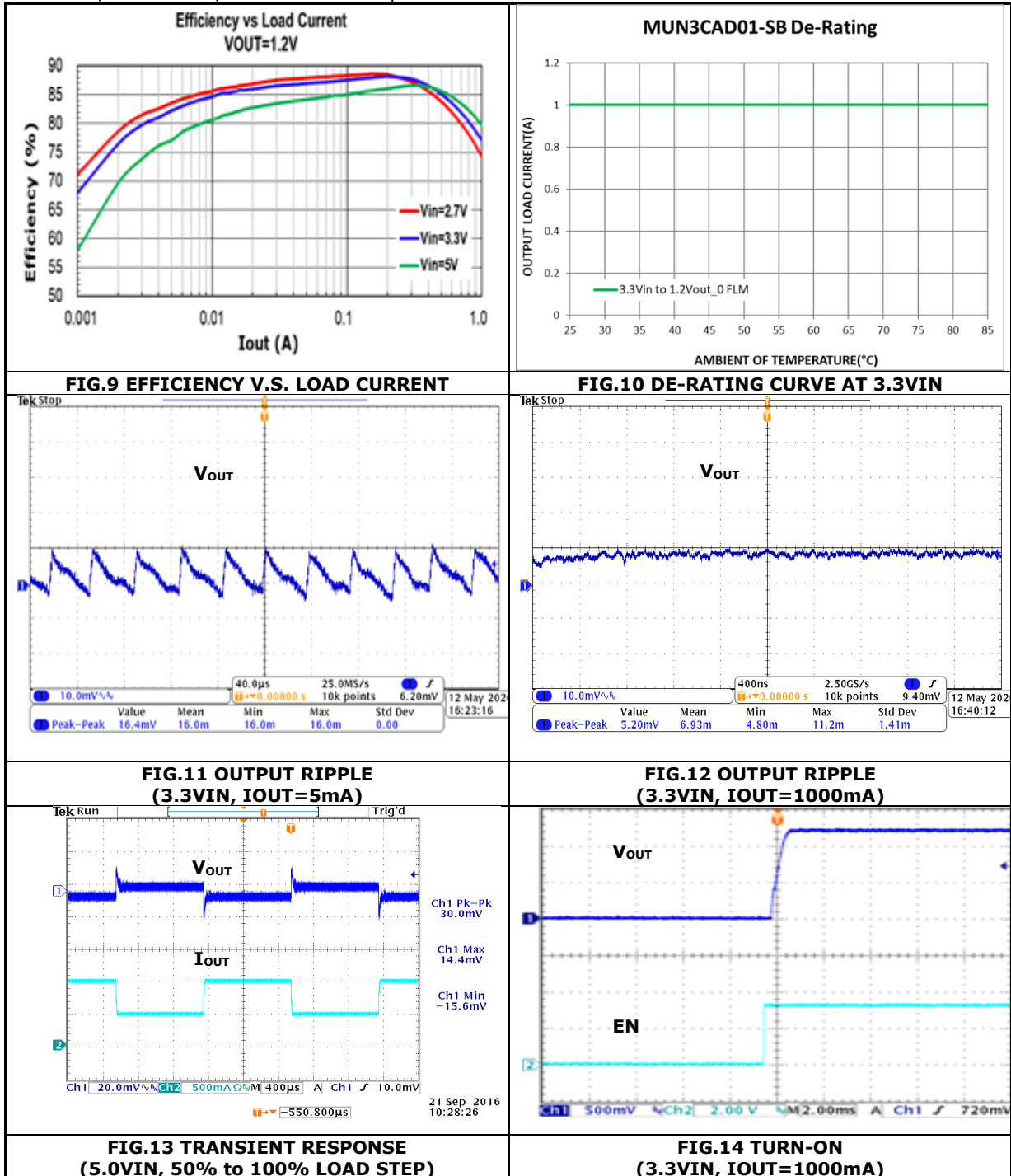

TYPICAL PERFORMANCE CHARACTERISTICS: (1.5VOUT)

Conditions: $T_A = 25^\circ\text{C}$, unless otherwise specified. Test Board Information: 30mm×30mm×1.6mm, 4 layers 20z .

The output ripple and transient response measurement is short loop probing and 20MHz bandwidth limited. $V_{in} = 3.3\text{V}$, $V_{out} = 1.5\text{V}$, unless otherwise specified.

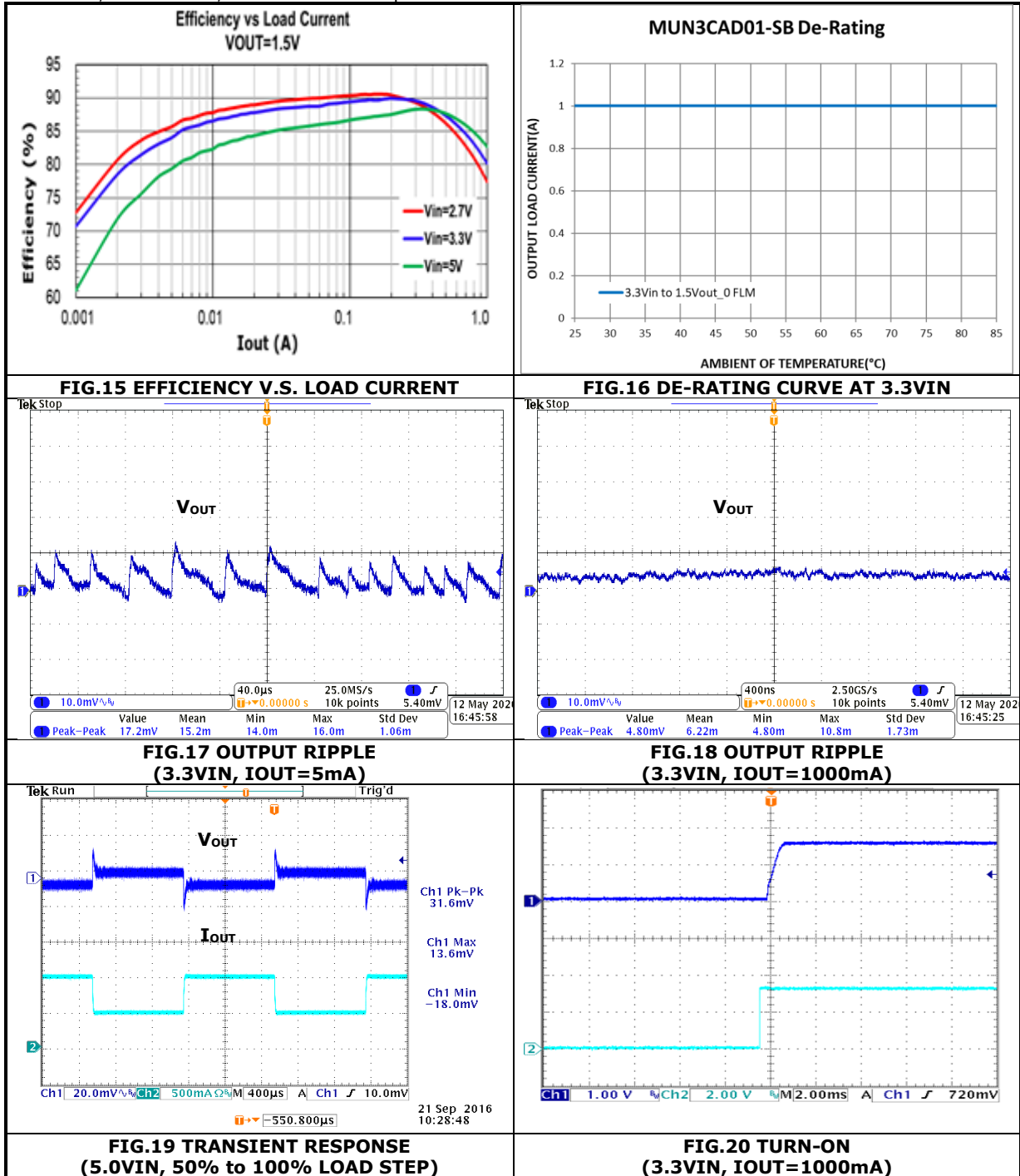

TYPICAL PERFORMANCE CHARACTERISTICS: (1.8VOUT)

Conditions: $T_A = 25\text{ }^\circ\text{C}$, unless otherwise specified. Test Board Information: 30mm×30mm×1.6mm, 4 layers 20z .

The output ripple and transient response measurement is short loop probing and 20MHz bandwidth limited. $V_{in} = 3.3\text{V}$, $V_{out} = 1.8\text{V}$, unless otherwise specified.

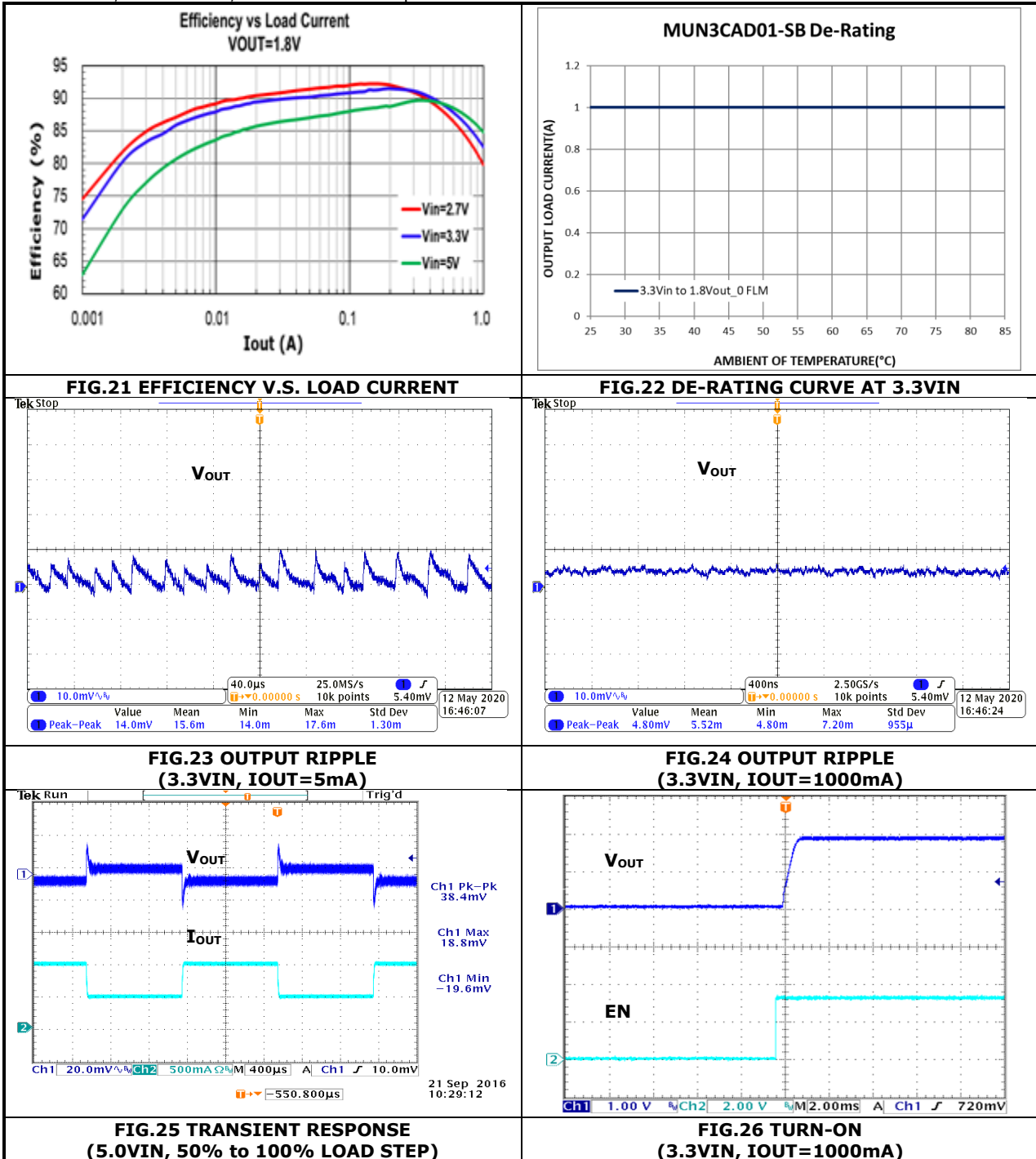

TYPICAL PERFORMANCE CHARACTERISTICS: (2.5VOUT)

Conditions: $T_A = 25\text{ }^\circ\text{C}$, unless otherwise specified. Test Board Information: 30mm×30mm×1.6mm, 4 layers 20z .

The output ripple and transient response measurement is short loop probing and 20MHz bandwidth limited. $V_{in} = 3.3\text{V}$, $V_{out} = 2.5\text{V}$, unless otherwise specified.

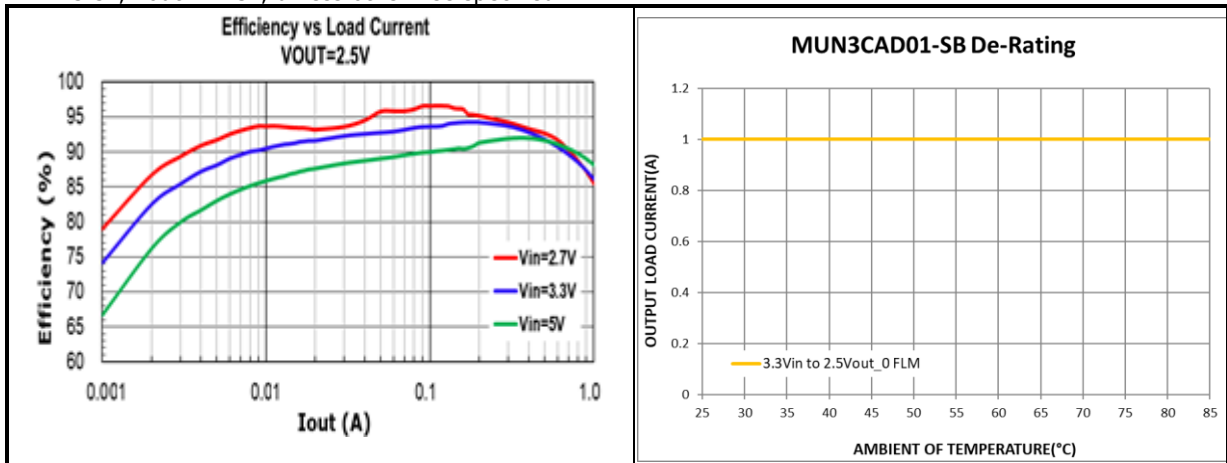

FIG.27 EFFICIENCY V.S. LOAD CURRENT

FIG.28 DE-RATING CURVE AT 3.3VIN

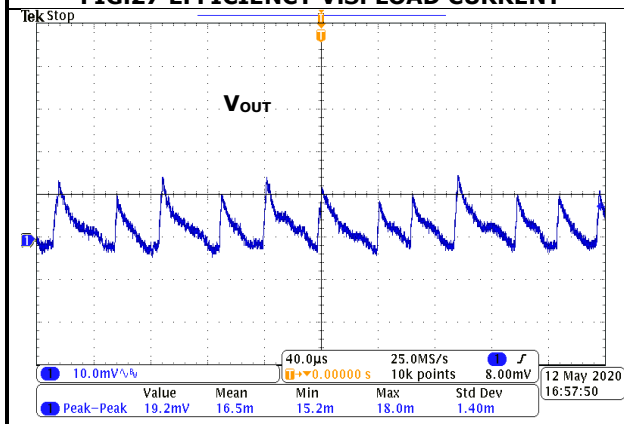

FIG.29 OUTPUT RIPPLE (3.3VIN, IOUT=5mA)

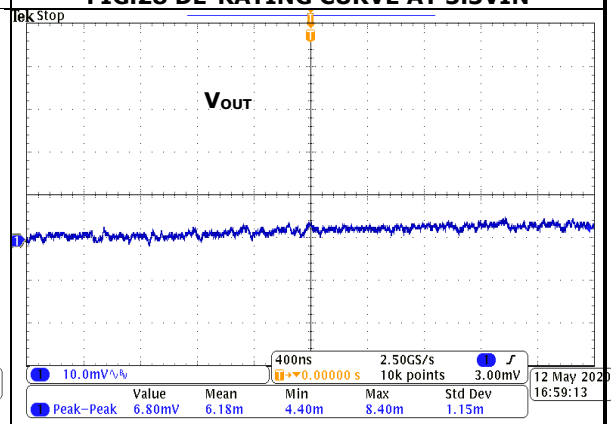

FIG.30 OUTPUT RIPPLE (3.3VIN, IOUT=1000mA)

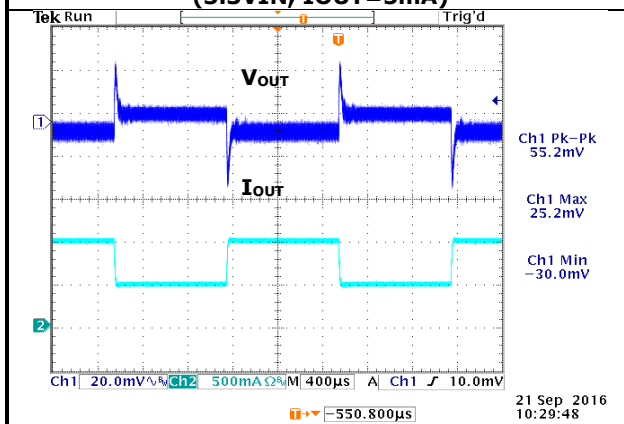

FIG.31 TRANSIENT RESPONSE (5.0VIN, 50% to 100% LOAD STEP)

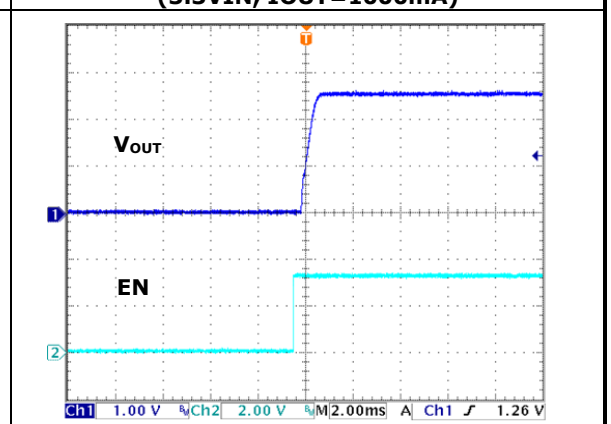
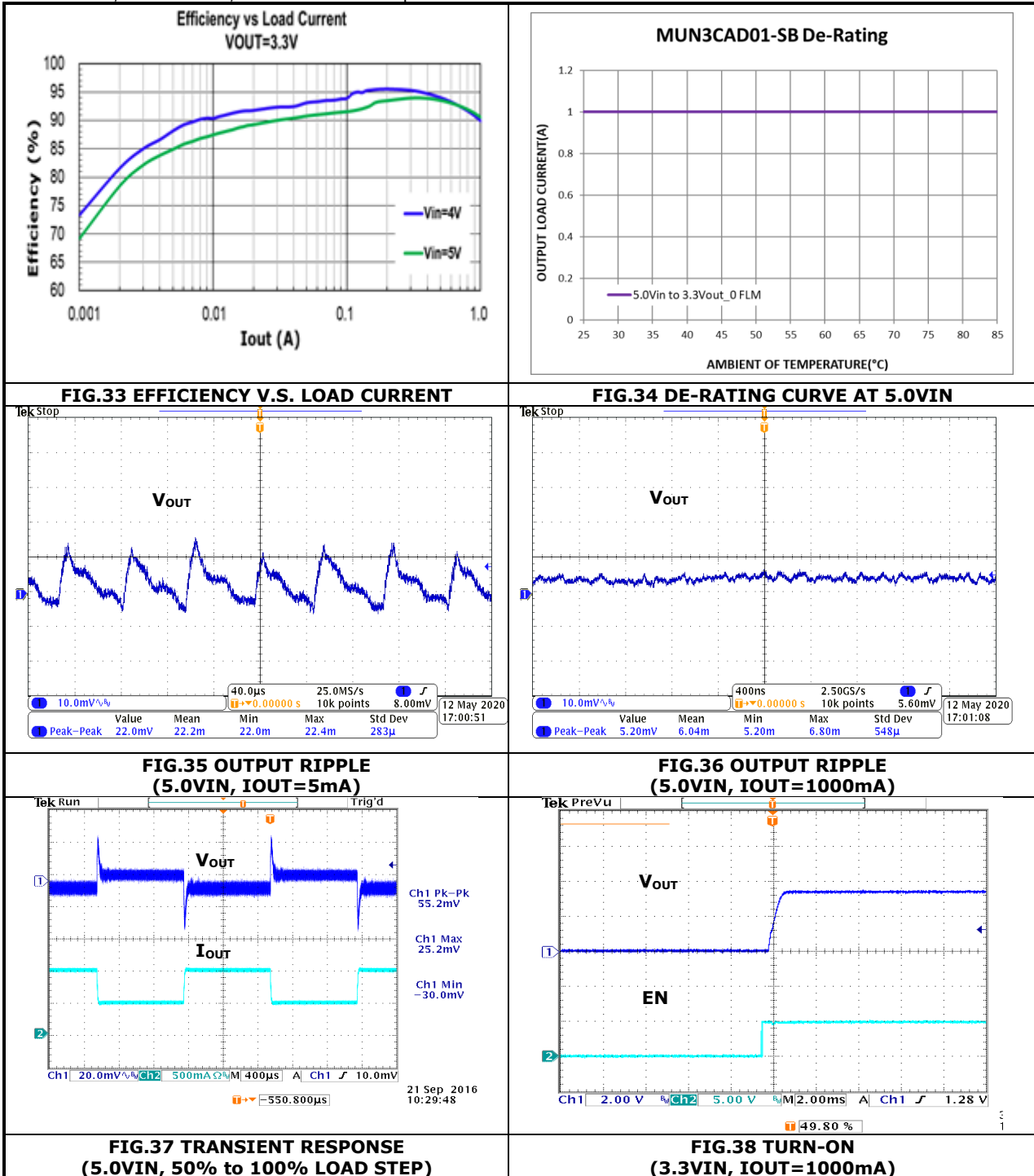

FIG.32 TURN-ON (3.3VIN, IOUT=1000mA)

TYPICAL PERFORMANCE CHARACTERISTICS: (3.3VOUT)

Conditions: $T_A = 25\text{ }^\circ\text{C}$, unless otherwise specified. Test Board Information: 30mm×30mm×1.6mm, 4 layers 20z .

The output ripple and transient response measurement is short loop probing and 20MHz bandwidth limited. $V_{in} = 5.0\text{V}$, $V_{out} = 3.3\text{V}$, unless otherwise specified.



APPLICATIONS INFORMATION:

REFERENCE CIRCUIT FOR GENERAL APPLICATION:

The Figure 39 shows the module application schematics for input voltage +5V or +3.3V and turn on by input voltage directly through enable resistor (REN).

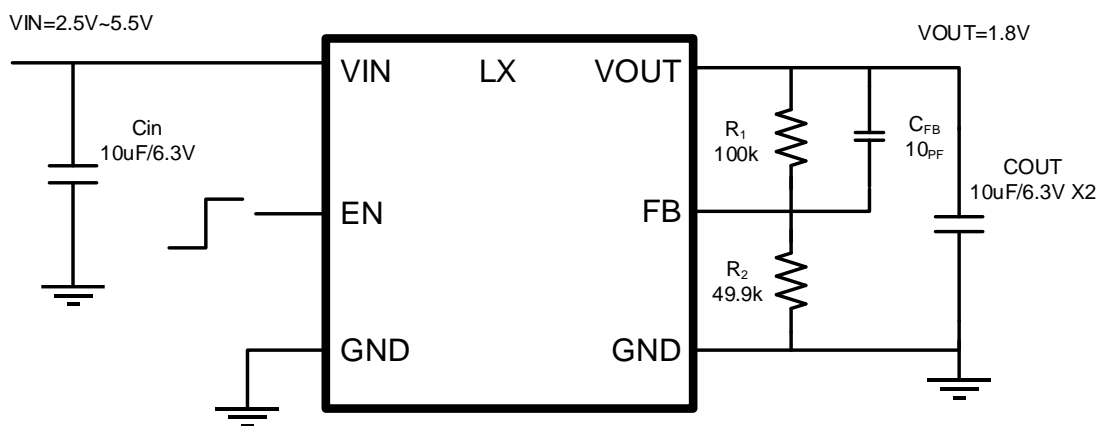

F

FIG.39 TYPICAL APPLICATION FOR PWM OPERATION

APPLICATIONS INFORMATION: (Cont.)**SAFETY CONSIDERATIONS:**

Certain applications and/or safety agencies may require fuses at the inputs of power conversion components. Fuses should also be used when there is the possibility of sustained input voltage reversal which is not current limited. For greatest safety, we recommend a fast blow fuse installed in the ungrounded input supply line. The installer must observe all relevant safety standards and regulations. For safety agency approvals, install the converter in compliance with the end-user safety standard.

INPUT FILTERING:

The module should be connected to a low AC impedance source supply and a highly inductive source or line inductance can affect the stability of the module. An input capacitor must be placed directly to the input pin of the module, to minimize input ripple voltage and ensure module stability.

OUTPUT FILTERING:

To reduce output ripple and improve the dynamic response as the step load changes, an additional capacitor at the output must be connected. Low ESR polymer and ceramic capacitors are recommended to improve the output ripple and dynamic response of the module.

PROGRAMMING OUTPUT VOLTAGE:

The module has an internal 0.6V $\pm 2\%$ reference voltage. The output voltage can be programmed by the dividing resistor R1 and R2 which respects to VOUT pin and FB pin. The output voltage can be calculated as shown in Equation 1 and the resistor according to typical output voltage is shown in TABLE 1.

$$V_{OUT}(V) = 0.6 \times \left(1 + \frac{R1}{R2} \right) \quad (EQ.1)$$

APPLICATIONS INFORMATION: (Cont.)

RECOMMENDATION LAYOUT GUIDE:

In order to achieve stable, low losses, less noise or spike, and good thermal performance some layout considerations are necessary. The recommendation layout is shown as Figure 40.

1. The ground connection between pin 2 and 6 should be a solid ground plane under the module. It can be connected one or more ground plane by using several Vias.
2. Place high frequency ceramic capacitors between pin 7 (VIN), and pin 2, 6 (GND) for output side, as close to module as possible to minimize high frequency noise.
3. Place high frequency ceramic capacitors between pin 8 (VOUT), and pin 2, 6 (GND) for output side, as close to module as possible to minimize high frequency noise.
4. Keep the R_1 , R_2 , and C_{FB} connection trace to the module pin 3 (FB) short.
5. Use large copper area for power path (VIN, VOUT, and GND) to minimize the conduction loss and enhance heat transferring. Also, use multiple Vias to connect power planes in different layer.

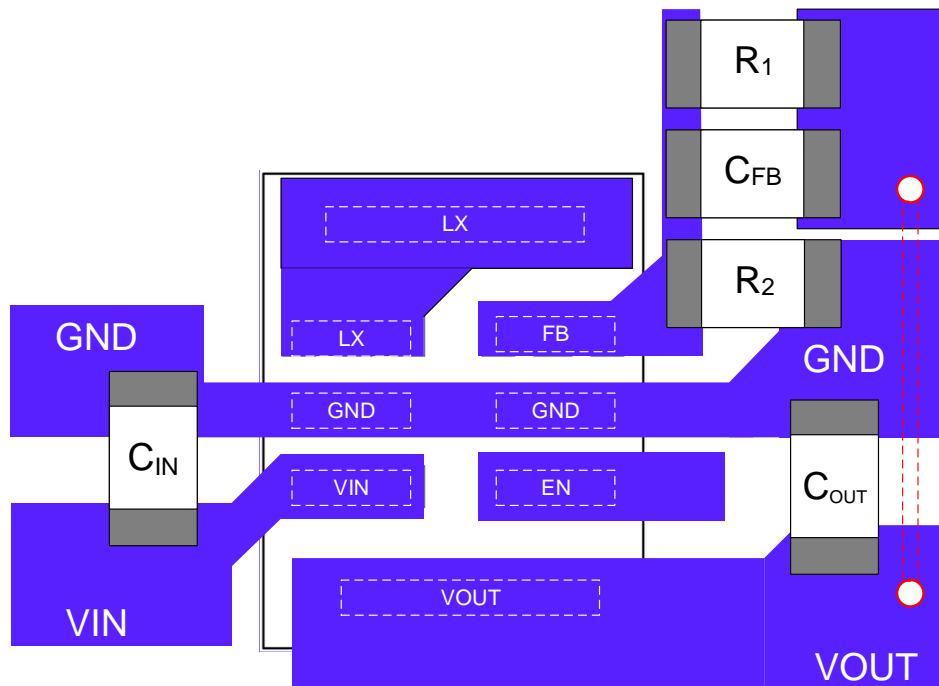

FIG.40 RECOMMENDATION LAYOUT (TOP LAYER)

APPLICATIONS INFORMATION: (Cont.)

Thermal Considerations:

All of thermal testing condition is complied with JEDEC EIJ/JESD 51 Standards. Therefore, the test board size is 30mm×30mm×1.6mm with 4 layers 2oz. The case temperature of module sensing point is shown as Figure 41. Then $R_{th(j_{choke}-a)}$ is measured with the component mounted on an effective thermal conductivity test board on 0 LFM condition. The MUN3CAD01-SB module is designed for using when the case temperature is below 110°C regardless the change of output current, input/output voltage or ambient temperature.

Sensing point (Defined case temperature)

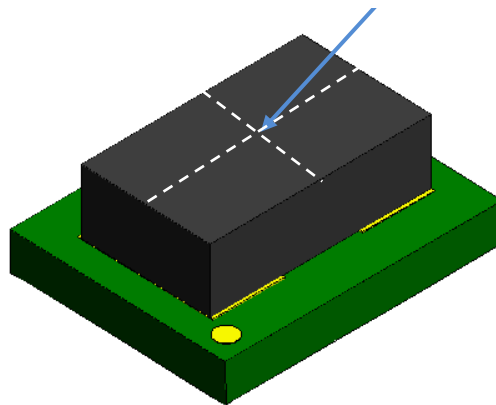
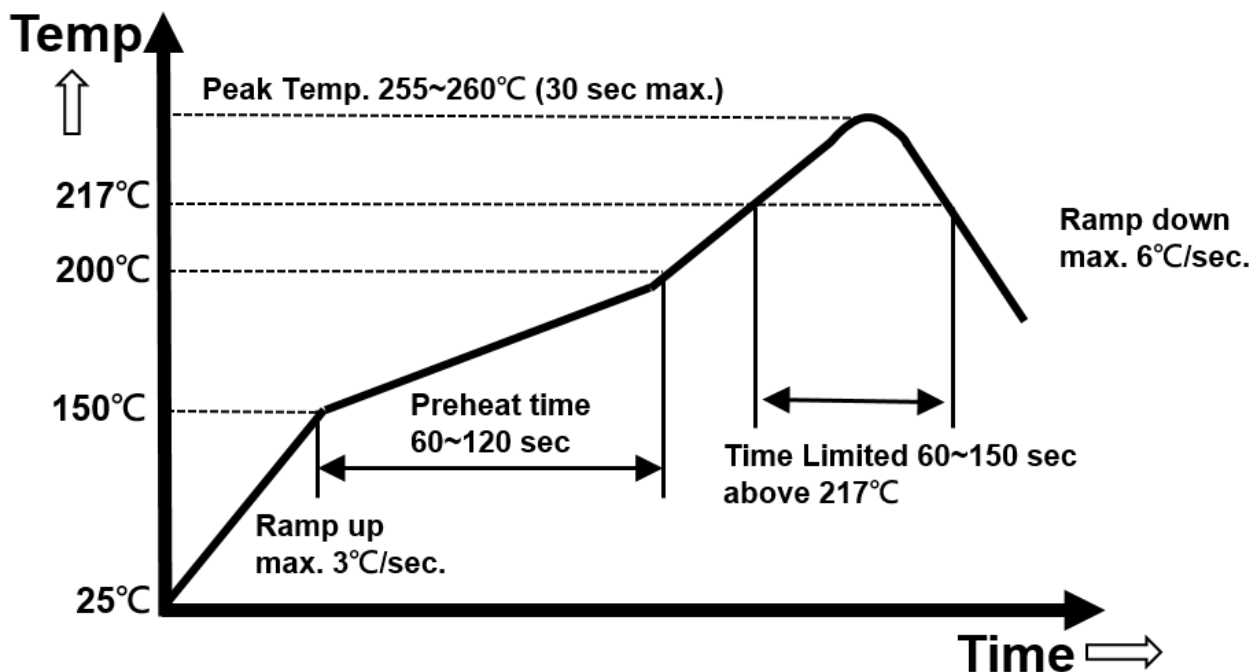

FIG.41 Case Temperature Sensing Point

REFLOW PARAMETERS:

Lead-free soldering process is a standard of electronic products production. Solder alloys like Sn/Ag, Sn/Ag/Cu and Sn/Ag/Bi are used extensively to replace the traditional Sn/Pb alloy. Sn/Ag/Cu alloy (SAC) is recommended for this power module process. In the SAC alloy series, SAC305 is a very popular solder alloy containing 3% Ag and 0.5% Cu and easy to obtain. Figure 42 shows an example of the reflow profile diagram. Typically, the profile has three stages. During the initial stage from room temperature to 150°C, the ramp rate of temperature should not be more than 3°C/sec. The soak zone then occurs from 150°C to 200°C and should last for 60 to 120 seconds. Finally, keep at over 217°C for 60~150 seconds to melt the solder and make the peak temperature at the range from 255°C to 260°C (Do not exceed 30 sec). It is noted that the time of peak temperature should depend on the mass of the PCB board. The reflow profile is usually supported by the solder vendor and one should adopt it for optimization according to various solder type and various manufacturers' formulae.

FIG.42 Recommendation Reflow Profile
(Not to scale)

***Refer to the Classification Reflow Profile of J-STD-020.**

PACKAGE OUTLINE DRAWING:

Unit: mm

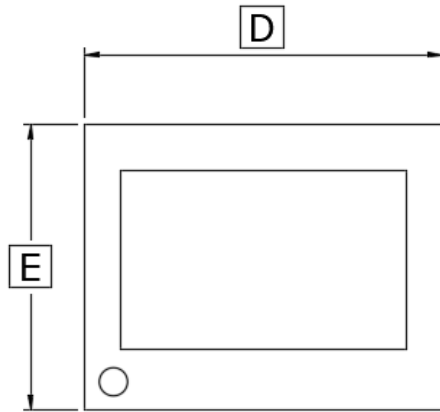

TOP VIEW

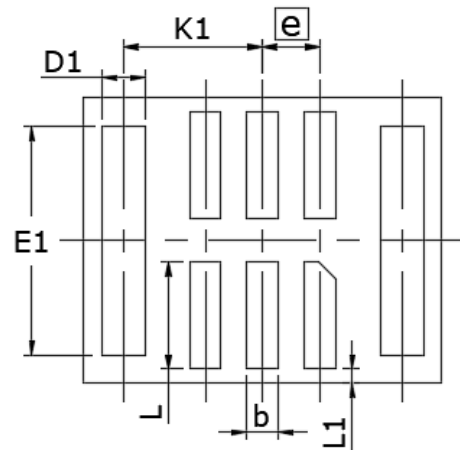

BOTTOM VIEW

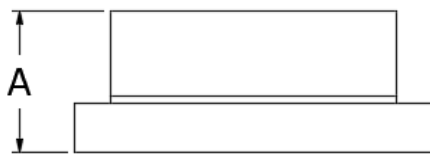

SIDE VIEW

DIM	MILLIMETERS		
	MIN	NOM	MAX
A	-	1.00	1.10
b	0.14	0.20	0.26
D	2.40	2.50	2.60
E	1.90	2.00	2.10
e	0.35	0.40	0.45
D1	0.24	0.30	0.36
E1	1.50	1.60	1.70
L	0.68	0.75	0.77
L1	0.00	0.10	0.20
K1	0.87	0.97	1.07

LAND PATTERN REFERENCE:

Unit: mm

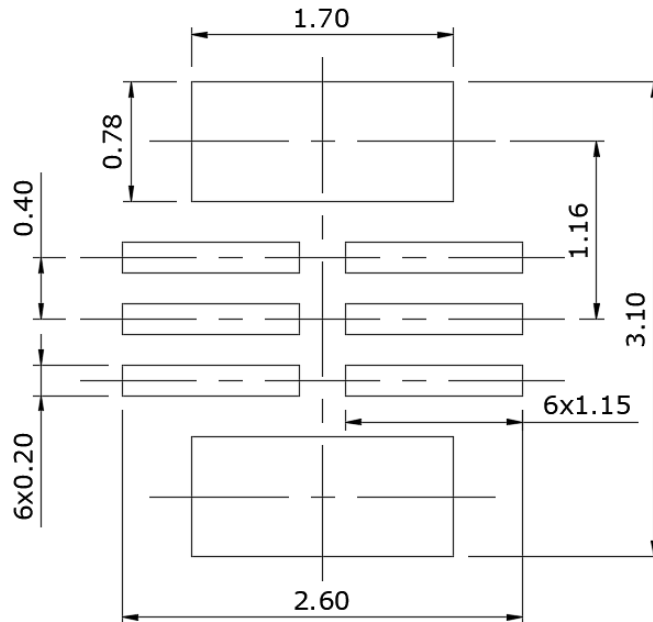

RECOMMENDED LAND PATTERN

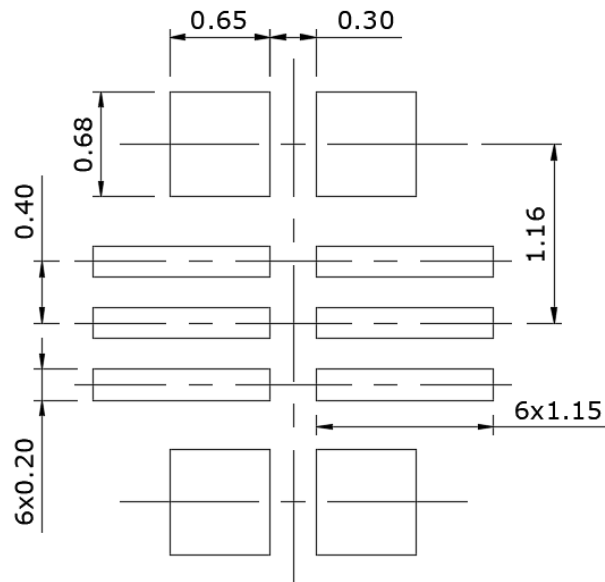

RECOMMENDED STENCIL PATTERN

*Based on 0.1~0.15mm thickness stencil (Reference only)

*Recommended solder paste coverage 55~100%

PACKING REFERENCE:

Unit: mm

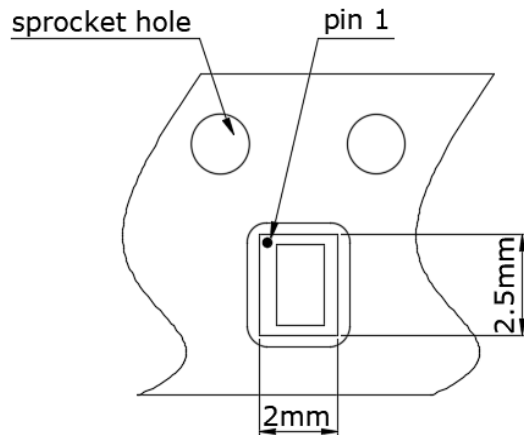
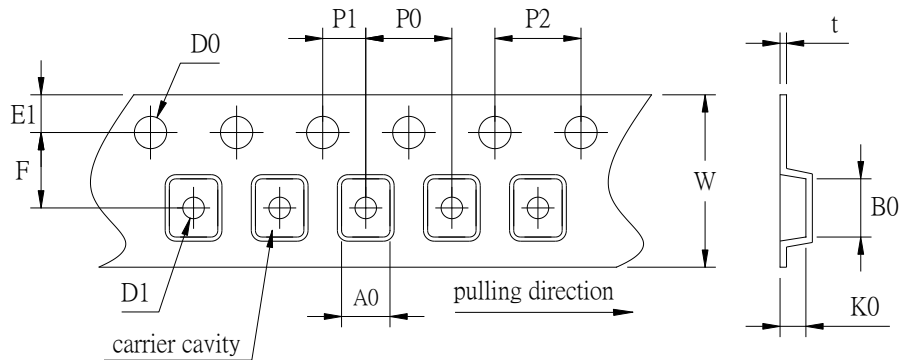
Package In Tape Loading Orientation

Tape Dimension

A0	2.32 ± 0.10	E1	1.75 ± 0.10
B0	2.82 ± 0.10	K0	1.15 ± 0.10
F	3.50 ± 0.05	P0	4.00 ± 0.10
W	$8.00 +0.30/-0.10$	P1	2.00 ± 0.05
D0	$\phi 1.50 +0.1/-0.0$	P2	4.00 ± 0.10
D1	$\phi 1.0 \text{ Min.}$	t	0.25 ± 0.05

PACKING REFERENCE: (Cont.)

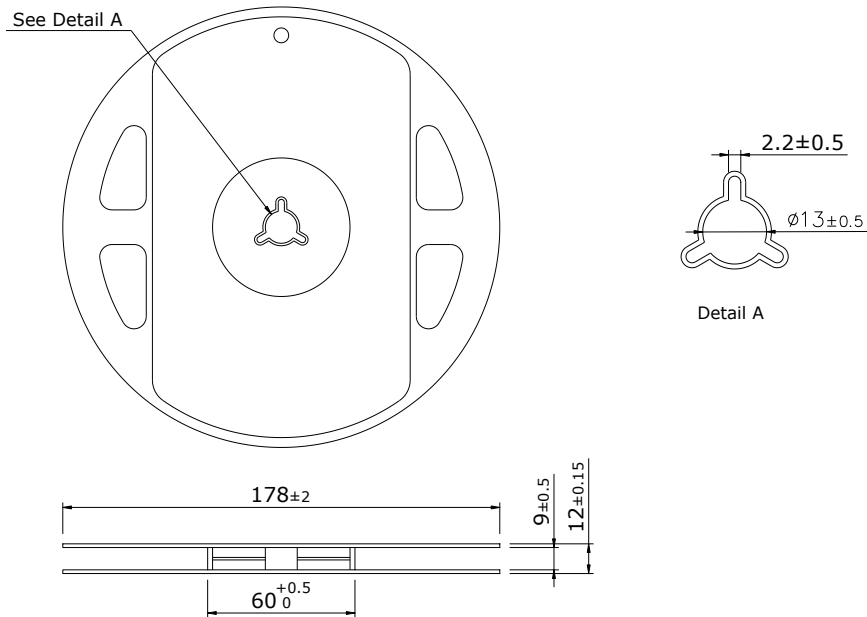
Unit: mm

Reel Dimension

Peel Strength of Top Cover Tape

The peel speed shall be about 300mm/min.

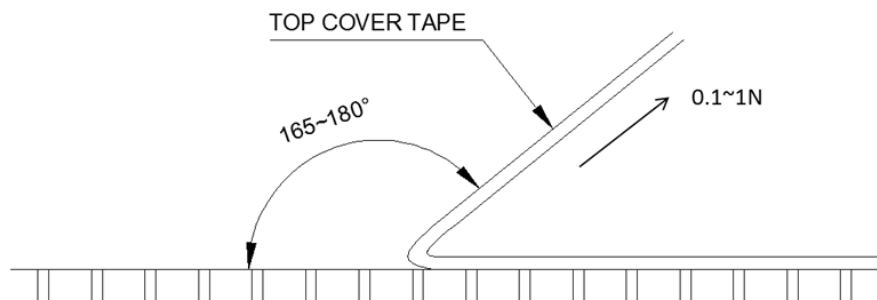
The peel force of top cover tape shall between 0.1N to 1.0N



REVISION HISTORY:

Date	Revision	Changes
2020.05.13	00	1 ∙ Initial released.
2020.06.03	01	1 ∙ Upgrade output current 1A to 1.2A
2020.07.23	02	1 ∙ Upgrade $R_{th(jchoke-a)}$
2020.10.13	03	1 ∙ Update $I_{OUT(DC)}$ 1000mA→1200mA 2 ∙ Upgrade Lead pattern information
2020.10.13	04	1 ∙ Update $I_{OUT(DC)}$ 1200mA→1000mA
2021.11.16	05	1 ∙ Update $I_{S(IN)}$ 610mA→480mA
2022.02.23	06	1 ∙ Update P/N 2 ∙ Modify typo in efficiency curve
2022.06.07	07	1 ∙ Update De-rating Curve
2022.12.19	08	1 ∙ Page 15, add test board information "2oz". Change board size from 2 layers to 4 layers. 2 ∙ Page 16, update reflow parameters and FIG.42. 3 ∙ Page 18, change the thickness description of stencil and add note.