

The history of revision change for the specification

Document	REV.	Modified date	Description
CYNVC-175-020	A0	2017.5.25	New Approval
CYNVC-175-020	A1	2017.6.13	1. May -> Jun. 2. Add spec of R24, R56, R68, R82, 1R5 3. Add curve of R24, R56, R68, R82, 1R5
CYNVC-175-020	A2	2017.8.25	1. Jun. -> Aug. 2. Remove spec of R24, R50, R56, R68, R82, 1R5 3. Remove curve of R24, R50, R56, R68, R82, 1R5
CYNVC-175-020	A3	2017.10.20	1. Aug. -> Oct. 2. Add spec of 1R5
CYNVC-175-020	A4	2018.3.13	1. Oct., 2017 -> Mar., 2018 2. Add curve of 1R5 3. Add "AEC-Q200" logo on page 2
CYNVC-175-020	A5	2018.8.7	1. Mar. -> Aug.. 2. Add spec of R24
CYNVC-175-020	A6	2018.10.2	1. Aug. -> Oct. 2. Remove spec of R24, 100 3. Add Rated voltage on page 3
CYNVC-175-020	A7	2019.9.12	1. Oct., 2018 -> Sep., 2019 2. Add spec & curve of R56
CYNVC-175-020	A8	2020.2.24	1. Sep., 2019 -> Feb., 2020 2. Add spec & curve of R50
CYNVC-175-020	A9	2020.4.20	1. Feb. -> Apr. 2. Add spec & curve of R68
CYNVC-175-020	B0	2020.5.22	1. Apr. -> May 2. Add spec & curve of R24
CYNVC-175-020	B1	2020.10.21	1. May -> Oct. 2. Add spec & curve of R10
CYNVC-175-020	B2	2021.5.11	1. Oct., 2020 -> May, 2021 2. Add spec & curve of 100
CYNVC-175-020	B3	2021.08.31	1. May. -> Sep. 2. Update R15 Idc. & Isat. & curve Idc.(typ/max):6.1/5.4 -> 7.9/7.1 Isat.(typ/max):7.5/6.4 -> 11.7/10.0
CYNVC-175-020	B4	2024.09.26	1. 2021 -> 2024 2. Add notice 'Shielded construction' in Features 3. Reflow Soldering : 217°C -> ≥217°C

Power Choke Coil VCTA20161B MS6 type

AEC-Q200

■ **Features**

- High performance (Isat) realized by metal dust core
- Low profile : 2.0mm x 1.6mm x 1.2mm
- Low loss realized with low DCR
- Compliance with RoHS and Halogen Free
- Shielded construction
- AEC-Q200 qualified

■ **Application**

Automotive applications

■ **Outline Dimensions**

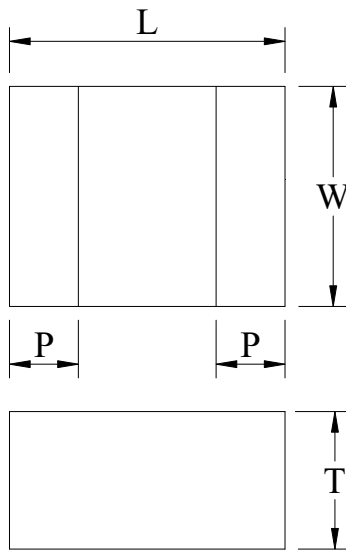

Code	Dimensions (mm)
L	2.0 ± 0.2
W	1.6 ± 0.2
T	1.2 Max.
P	0.5 ± 0.3

■ **Recommend Land Pattern Dimensions**

The customer shall determine the land dimensions shown below after confirming and safety.

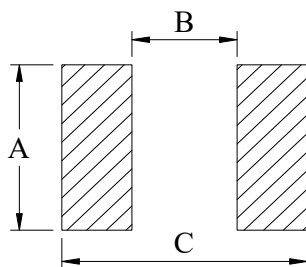

A	1.9
B	0.9
C	2.3

Unit : mm

■ Marking

The point on the top surface represents winding direction of choke.

Upside of Chip

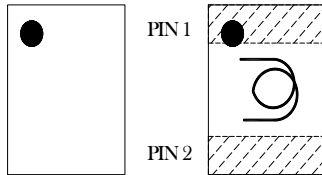

Coil clockwise around

■ Specifications

Part Number	L0 ◇ Inductance (μH) @ (0A)	R _{dc} (m Ω) ◇		Heat Rating Current DC Amps. I _{dc} (A)		Saturation Current DC Amps. I _{sat} (A)		Rated Voltage (V)
		Typical	Maximum	Typical	Maximum	Typical	Maximum	Maximum
VCTA20161B-R10MS6	0.10	5.0	9.0	9.0	6.5	10.0	9.0	20
VCTA20161B-R15MS6	0.15	11.0	14.0	7.9	7.1	11.7	10.0	20
VCTA20161B-R22MS6	0.22	15.0	18.0	5.8	5.2	7.7	6.6	20
VCTA20161B-R24MS6	0.24	14.0	17.0	5.5	5.0	6.6	6.0	20
VCTA20161B-R33MS6	0.33	19.0	23.0	4.7	4.2	5.9	5.1	20
VCTA20161B-R47MS6	0.47	21.0	25.0	4.5	4.0	5.4	4.8	20
VCTA20161B-R50MS6	0.50	25.0	30.0	4.2	3.8	4.7	4.0	20
VCTA20161B-R56MS6	0.56	29.0	35.0	4.0	3.6	4.4	3.8	20
VCTA20161B-R68MS6	0.68	31.0	40.0	3.9	3.4	4.1	3.6	20
VCTA20161B-1R0MS6	1.0	41.0	48.0	3.1	2.7	3.8	3.3	20
VCTA20161B-1R5MS6	1.5	67.0	80.0	2.5	2.3	3.2	2.8	20
VCTA20161B-2R2MS6	2.2	105.0	120.0	2.0	1.7	2.8	2.5	20
VCTA20161B-3R3MS6	3.3	210.0	250.0	1.3	1.2	1.8	1.5	20
VCTA20161B-4R7MS6	4.7	315.0	378.0	1.2	1.0	1.4	1.2	20
VCTA20161B-6R8MS6	6.8	560.0	670.0	0.8	0.7	1.1	1.0	20
VCTA20161B-100MS6	10.0	710.0	850.0	0.6	0.5	0.9	0.8	20

◇ : Significant Characteristic

Note 1. : Inductance tolerance $\pm 20\%$

Note 2. : All test data is referenced to 25°C ambient.

Note 3. : Test condition: 1MHz, 1.0V_{rms}

Note 4. : I_{dc} : DC current (A) that will cause an approximate ΔT of 40°C

Note 5. : I_{sat} : DC current (A) that will cause L0 to drop approximately 30%

Note 6. : Operating temperature range -55°C to +165°C

Note 7. : The part temperature (ambient + temp rise) should not exceed 165°C under the worst case operating conditions. Circuit design, component placement, PCB trace size and thickness, airflow and other cooling provision all affect the part temperature. Part temperature should be verified in the end application.

Note 8. : The rated current as listed is either the saturation current or the heating current depending on which value is lower.

Note 9. : Cleaning process note

(a) If this power choke is dipped in the cleaning agent, such as toluene, xylene, ketone, and ether system, there is a possibility that the performance decreases greatly.

(b) The high power ultrasonic washing may damage the choke body.

(c) Please contact us if you need the cleaning via the above agents or ultrasonic washing.

Note 10. : If you require another part number, please contact with us.

Current Characteristic

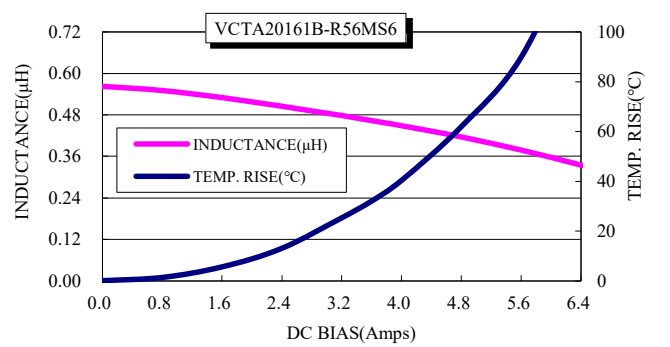
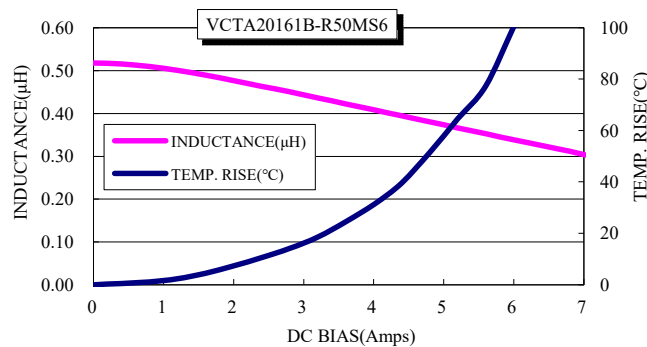
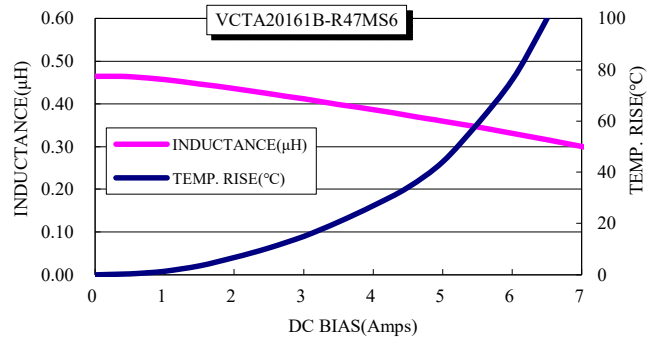
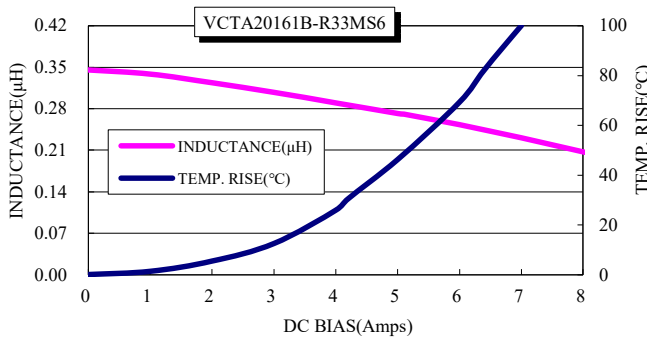
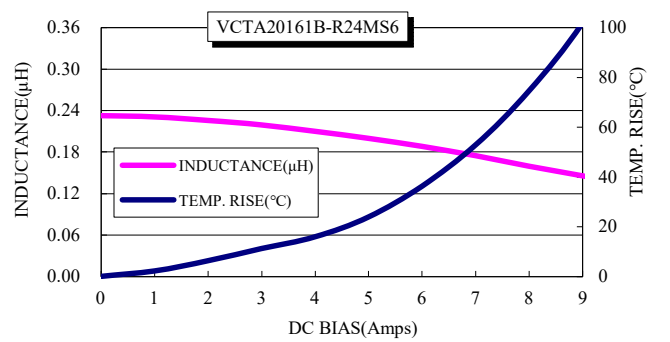
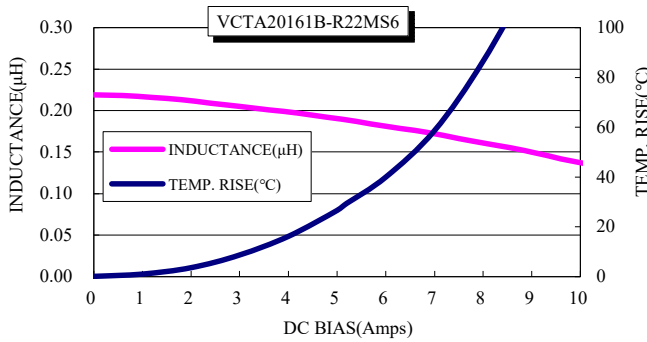
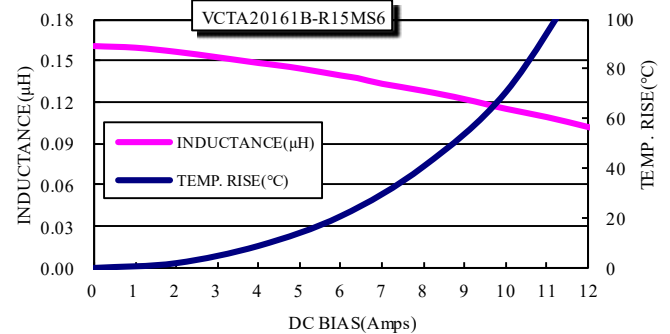
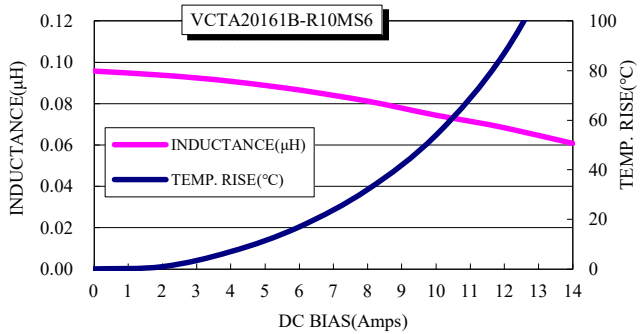

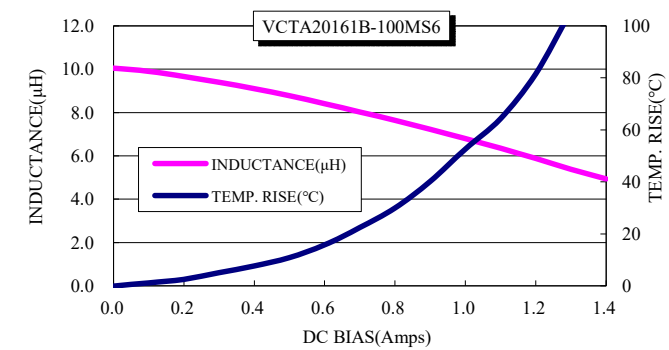
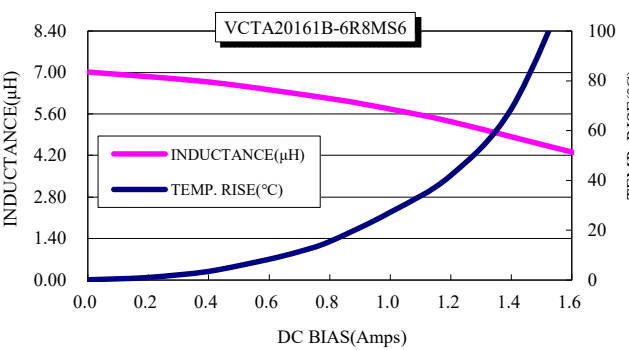
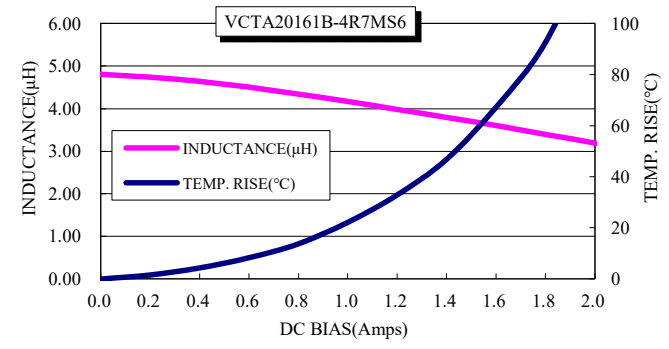
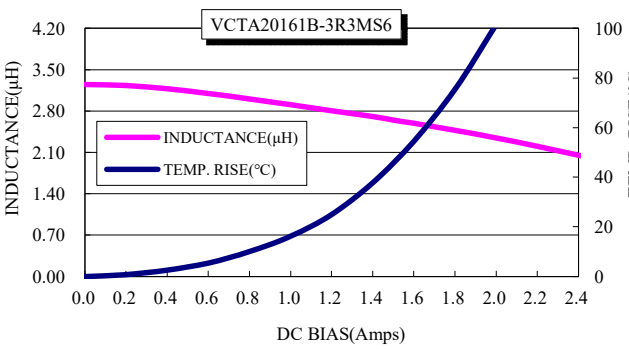
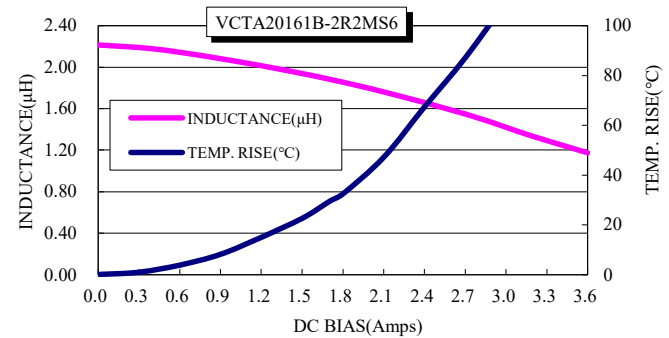
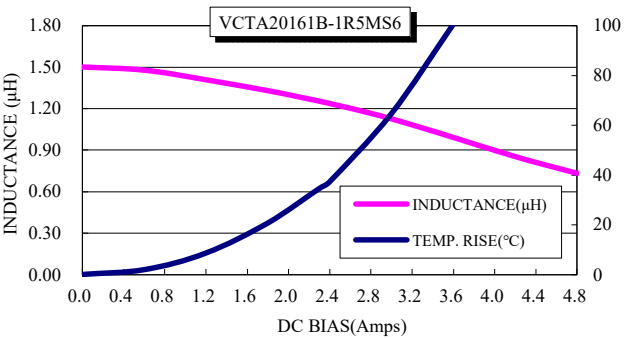
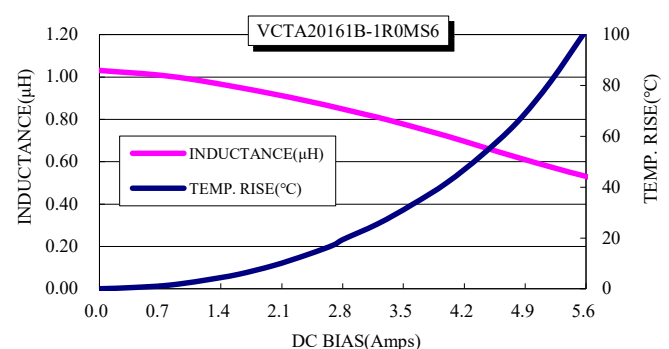
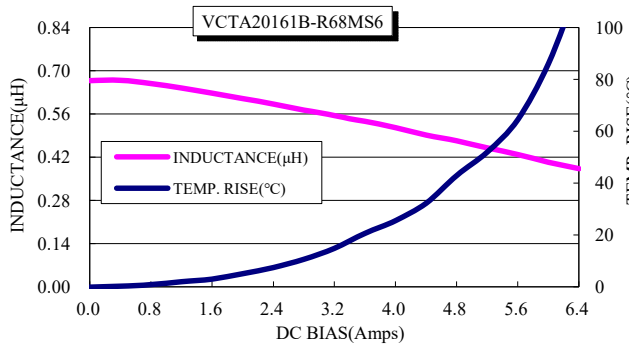

■ Packaging

(1) Tape packaging dimensions

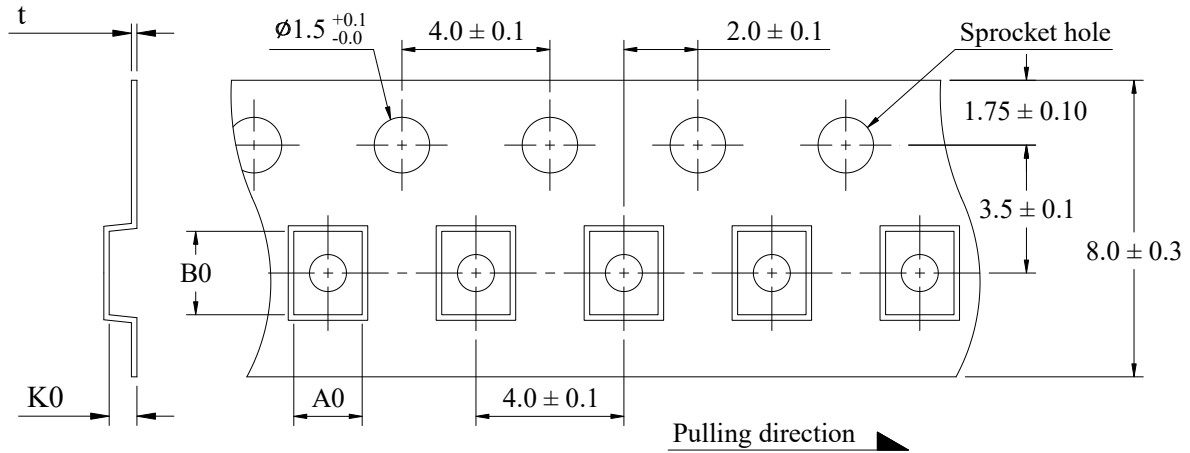

Dimensions Code (mm)				Units/Reel
A0	B0	K0	t	
1.85 ± 0.10	2.25 ± 0.10	1.35 ± 0.10	0.25 ± 0.05	2,000

(2) Tape direction

The direction shall be seen from the top cover tape side.

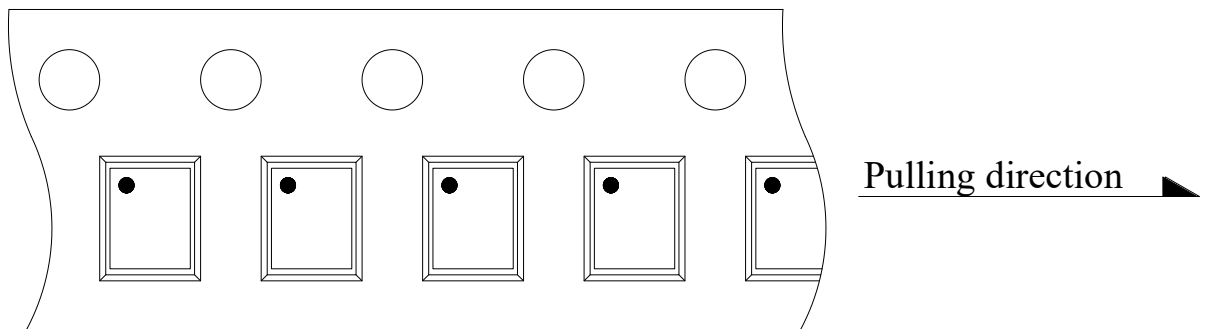

(3) Reel dimensions

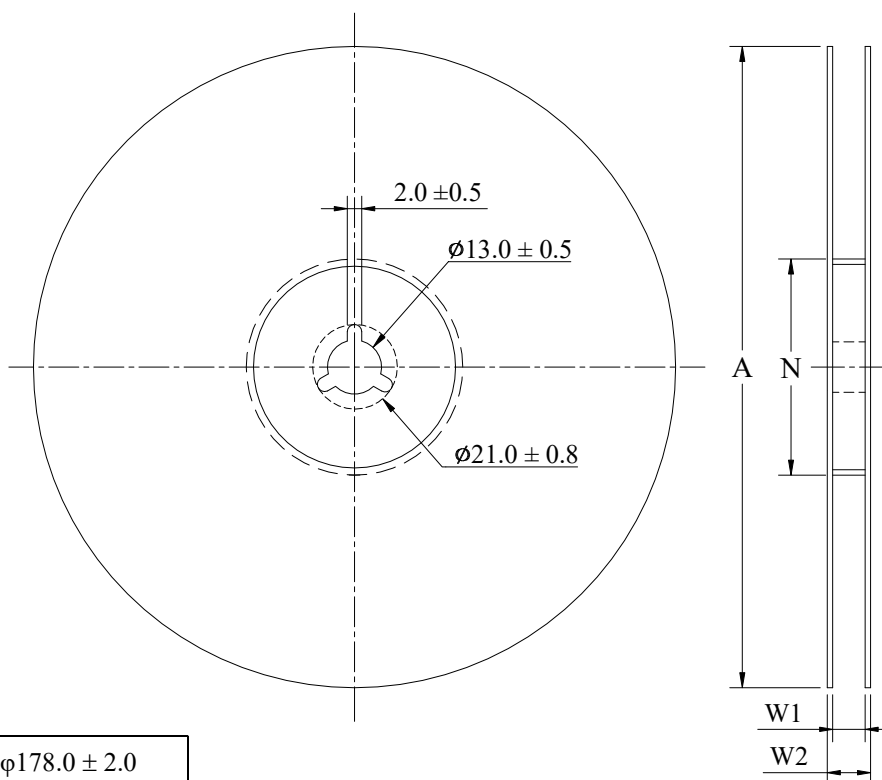

A	$\phi 178.0 \pm 2.0$
N	$\phi 60.0 \pm 2.0$
W1	9.0 ± 0.3
W2	11.4 ± 1.0

Unit : mm

(4) Peel force of top cover tape

The peel speed shall be about 300 mm/minute.

The peel force of top cover tape shall be between 0.1 to 0.7N.

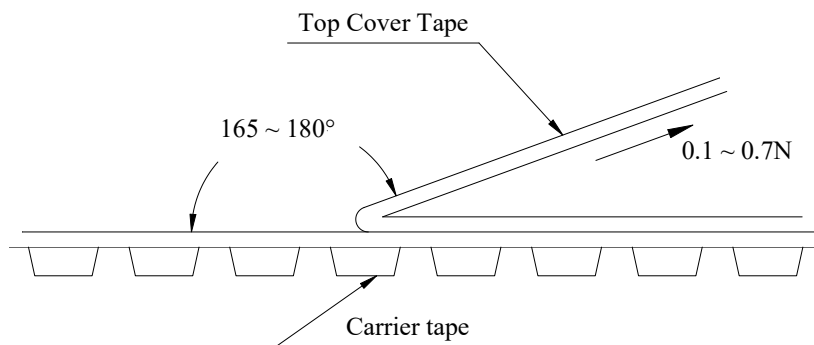

■ Reflow Profile

Power Choke Coil Type

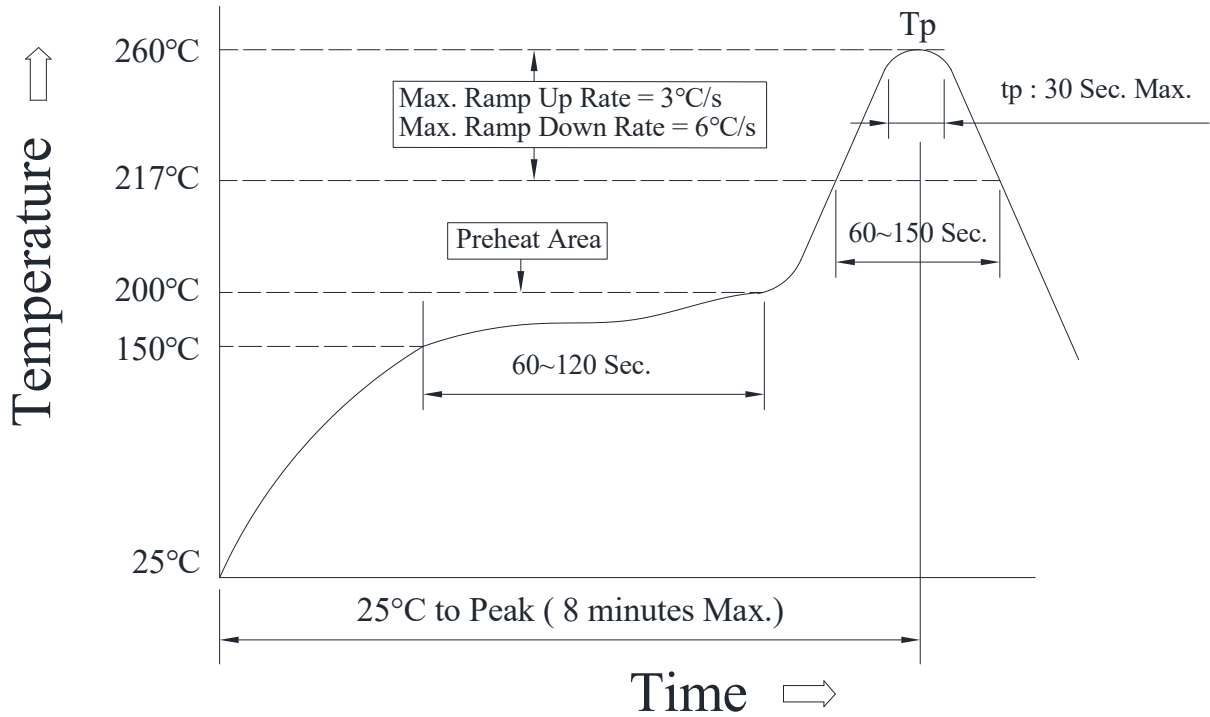

(1) Reflow soldering method :

Reflow Soldering	Tp : 255~260°C	Max. 30 seconds (tp)
	≥ 217°C	60~150 seconds
Preheat	150~200°C	60~120 seconds
Time 25°C to peak temperature	8 minutes Max.	

(2) Soldering iron method : 350 ± 5°C, 3 seconds Max.