

2W, 2512, Low Resistance Chip Resistor (Lead / Halogen Free)

1. Scope

This specification applies to 6.35mm x 3.2mm size 2W.

2. Features / Applications

- Welding construction; excellent long-term stability
- Ideal for all types of current sensing, voltage division and pulse applications
- Automotive applications & Current Sensor Resistor
- RoHS compliant

3. Type Designation

V S M L 2512 S 2 — □ □ □ □ □
 (1) (2) (3) (4) (5) (6)

Where

(1) Series No.

(2) Size

(3) Terminal Type:

S = Short terminal type

(4) Power Rating:

2 = 2W

(5) Resistance value:

R010 = 0.01Ω, 0M30 = 0.0003Ω

(6) Tolerance

F = ±1%, G = ±2%, J = ±5%

4. Dimensions and schematic

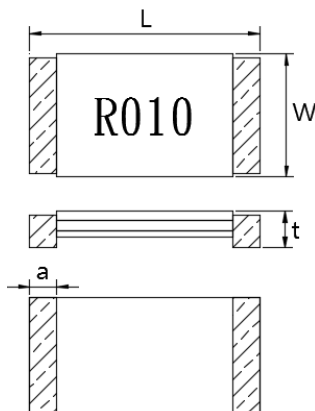

Dimensions (mm)	Resistance Range			
	0.3~0.9 mΩ	1~4.9 mΩ	5~6.9 mΩ	7~20 mΩ
L	6.35 ± 0.25			
W	3.20 ± 0.25			
t	0.60 ± 0.25			
a	2.55 ± 0.25	2.05 ± 0.25	1.15 ± 0.25	0.70 ± 0.25

Note: 0.3~0.9mΩ without marking

Figure 1. Construction and Dimensions

5. Specification

Characteristics	Feature			
Power Rating*	2W			
Resistance Value	0.5 ~ 20 mΩ			
Temperature Coefficient of Resistance	0.3~0.4 mΩ	0.5~0.9 mΩ	1~4.9 mΩ	5~20 mΩ
	± 125 ppm/°C	± 100 ppm/°C	± 75 ppm/°C	± 50 ppm/°C
Operation Temperature Range	-65°C ~ +170°C			
Resistance Tolerance	± 1%(F), ± 2%(G), ± 5%(J)			
Insulation Resistance	Over 100MΩ			
Maximum Working Voltage (V)	$(P \cdot R)^{1/2}$			

Note * :

Power rating is based on continuous full load operation at rated ambient temperature of 70°C. For resistors operated at ambient temperature in excess of 70°C, the maximum load shall be derated in accordance with the following curve.

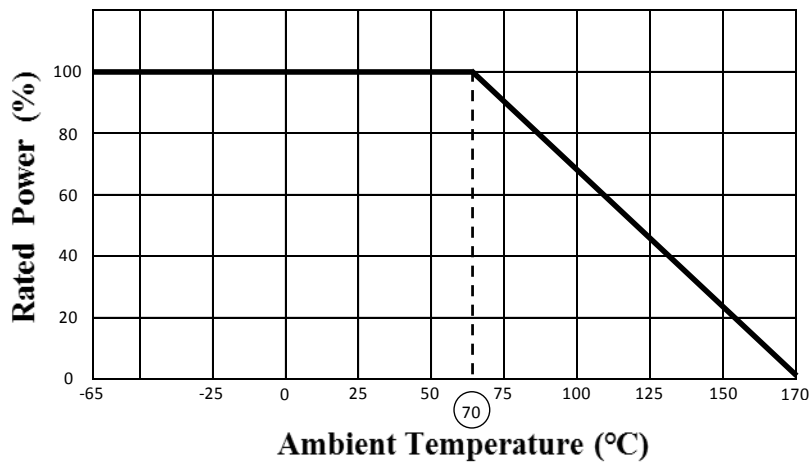

Figure 2. : Power Temperature Derating Curve

6. Characteristics

6-1 Electrical

Item	Specification and Requirement	Test Method
Temperature Coefficient (TCR)	As follow specification .	JIS-C-5201 +25°C/ +125°C
Short Time Overload	$\Delta R: \pm 0.5\%$ Without damage by flashover, spark, arcing, burning or breakdown	JIS-C-5201-1 4.13 2.5 x rated power for 5 seconds
Insulation Resistance	Over 100 M Ω on Overcoat layer face up	JIS-C-5201-1 4.6 100V _{DC} for 60 +10/-0 seconds
Voltage Proof	$\Delta R: \pm 1\%$ Without damage by flashover, spark, arcing, burning or breakdown	JIS-C-5201-1 4.7 400V _{AC} (rms.) for 60 +10/ -0 seconds
ESD	$\Delta R: \pm 1\%$	AEC-Q200-002 Human body, 3KV

6-2 Mechanical

Item	Specification and Requirement	Test Method
Solderability	The surface of terminal immersed shall be minimum of 95% covered with a new coating of solder	JIS-C-5201-1 4.17 245 ± 5°C for 3 ± 0.5 seconds
Resistance to Solder Heat	ΔR: ±0.5% Without distinct deformation in appearance	JIS-C-5201-1 4.18 260±5°C for 10± 1 seconds
Bending Test	ΔR: ±1.0% Without mechanical damage such as break	AEC-Q200-005 Bending value: 2 mm for 60 ± 1 seconds
Solvent Resistance	Without mechanical and distinct damage in appearance	MIL-STD-202 Method 215 Add Aqueous wash chemical - OKEM Clean or equivalent. Do not use banned solvents
Vibration	ΔR: ±0.5% Without mechanical damage such as break	MIL-STD-202 Method 204 5g's for 20 minutes, 12 cycles each of 3 orientations. Test from 10-2000Hz
Shock	ΔR: ±0.5% Without mechanical damage such as break	MIL-STD-202 Method 213 100g's peak value, 6ms, Half-sine waveform, 12.3ft/sec
Terminal Strength	ΔR: ±0.5% No visible damage	JIS-C-5201-1 Force of 1.8Kg for 60 seconds.

6-3 Endurance

Item	Specification and Requirement	Test Method
Temperature Cycling	$\Delta R: \pm 0.5\%$ Without distinct damage in appearance	JESD22 Method JA-104 1000 cycles, (-55°C~150°C) 30min maximum dwell time at each temperature.
Biased Humidity	$\Delta R: \pm 0.5\%$	MIL-STD-202 Method 103 1000 hours, 85°C/85%R.H, applied for 10% rated power Measurement at 24±4 hours after test conclusion.
Damp heat, steady state	$\Delta R: \pm 0.5\%$	IEC 60068-2 (40 ± 2) °C; (93 ± 3) % RH; 56 days
Load Life	$\Delta R: \pm 1.0\%$ Without distinct damage in appearance	MIL-STD-202 Method 108 70°C, 100% rated power 1.5 hours ON, 0.5 hours Off For total 1000 hours Measurement at 24±4 hours after test conclusion.
High Temperature Store	$\Delta R: \pm 1.0\%$ Without distinct damage in appearance	MIL-STD-202 Method 108 170°C for total 1,000 hours
Low temperature operation	$\Delta R: \pm 0.5\%$ Without distinct damage in appearance	-65°C for total 24 hours

7. Recommended Solder Pad Dimensions

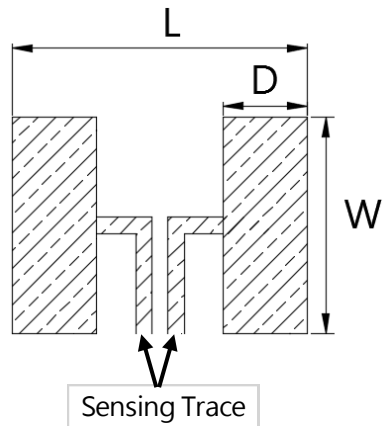

Resistance Range	Dimensions			
	W (mm)	L (mm)	D (mm)	t (μm)
0.3~4.9m Ω	3.7	7.35	3.20	140
5~6.9m Ω			2.10	
7~20m Ω			1.65	

t: Copper foil minimum thickness of PCB

8. Packaging

8-1 Dimensions

8-1-1 Tape packaging dimensions

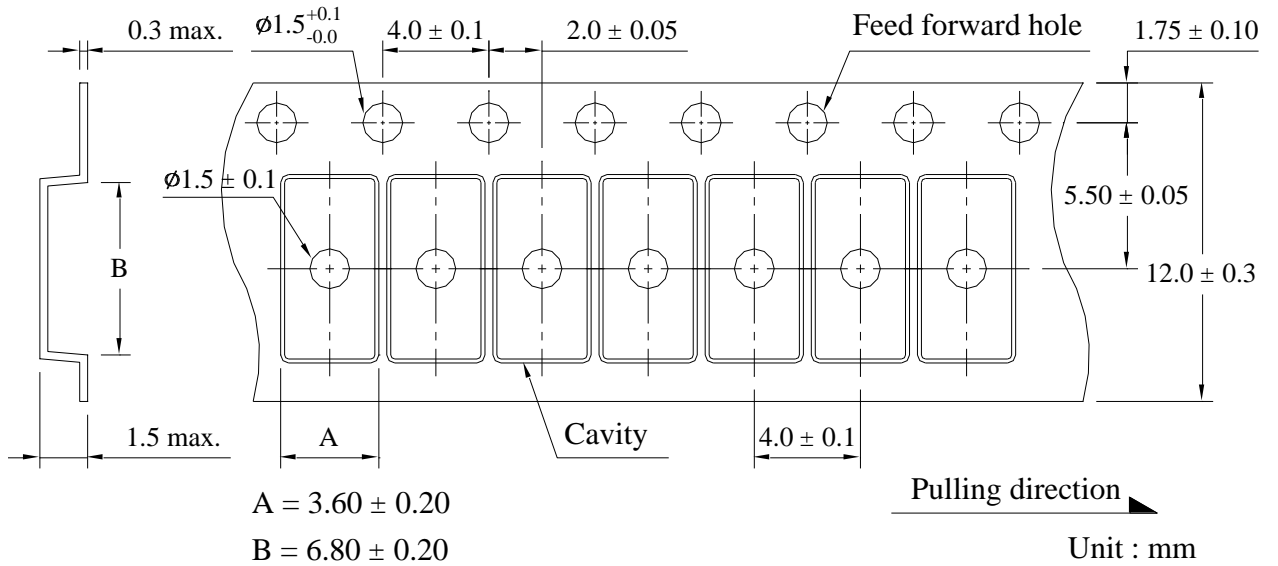

8-1-2 Reel dimensions

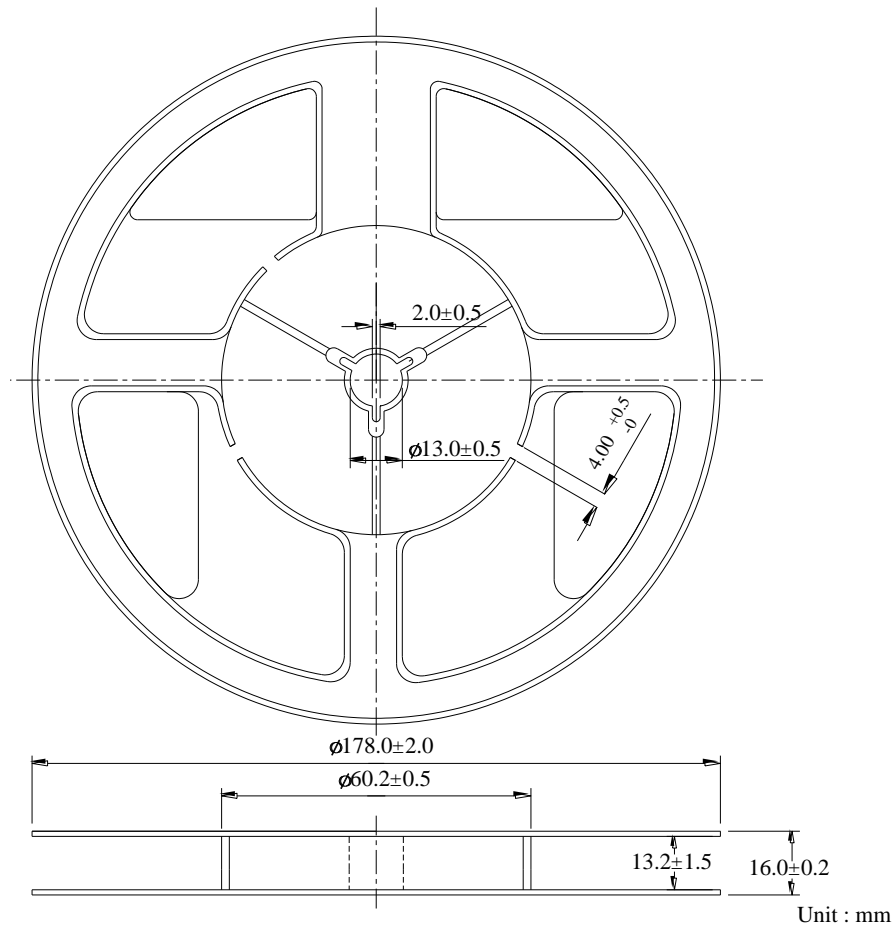

8-2 Peel Strength of Top Cover Tape

The peel speed shall be about 300mm/min.

The peel force of top cover tape shall between 0.1 to 0.7N

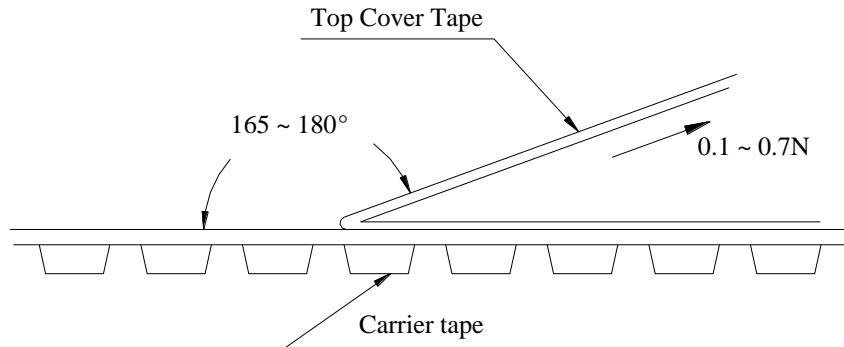

8-3 Number of Taping

2,000 pieces / reel

8-4 Label marking

The following items shall be marked on the reel.

- (1) Type designation
- (2) Quantity
- (3) Manufacturing date code
- (4) Manufacturer's name
- (5) The country of origin

9. Care note

9-1 Care note for storage

- (1) Chip resistor shall be stored in a room where temperature and humidity must be controlled. (temperature 5 to 35°C, humidity 45 to 85% RH) However, a humidity keep it low, as it is possible.
- (2) Chip resistor shall be stored as direct sunshine doesn't hit on it.
- (3) Chip resistor shall be stored with no moisture, dust, a material that will make solderability inferior, and a harmful gas (Chloridation hydrogen, sulfurous acid gas, and sulfuration hydrogen)

9-2 Care note for operating and handling

- (1) It is necessary to protect the edge and protection coat of resistors from mechanical stress.
- (2) Handle with care when printing circuit board (PCB) is divided or fixed on support body, because bending of printing circuit board (PCB) mounting will make mechanical stress for resistors.
- (3) Resistors shall be used with in rated range shown in specification. Especially, if voltage more than specified value will be loaded to resistor, there is a case it will make damage for machine because of temperature rise depending on generating of heat, and increase resistance value or breaks.
- (4) In case that resistor is loaded a rated voltage, it is necessary to confirms temperature of a resistor and to reduce a load power according to load reduction curve, because a temperature rise of a resistor depends on influence of heat from mounting density and neighboring element.
- (5) Observe Limiting element voltage and maximum overload voltage specified in each specification
- (6) If there is possibility that a large voltage (pulse voltage, shock voltage) charge to resistor, it is necessary that operating condition shall be set up before use.