

31mW, 0614, Resistor Network (Lead / Halogen Free)

Features / Applications :

- Lead-free, Halogen free.
- Telecommunication Equipment, Digital Cameras, Watches, Pocket Calculators, Computers, Instruments.
- RoHS compliant

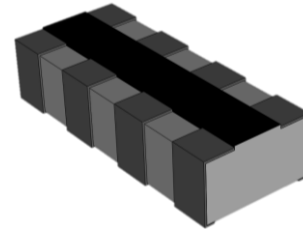

Electrical Specifications :

Power Rating*	Resistance Values Series	Resistance Tolerance	Resistance Range (Ω)	Temperature Coefficient of Resistance ppm /°C (Code)	Operating Temperature Range	Max. Operating Voltage**
31mW	E24 series	± 1.0% (F)	10~100K	± 200	-55°C to 125°C	12.5V
		± 5.0% (J)	10~1M			
Jumper	Resistance		Rated current		Operating Temperature Range	
	Below 50 mΩ		1A		-55°C to 125°C	

Note: *Package Power Temperature Derating Curve

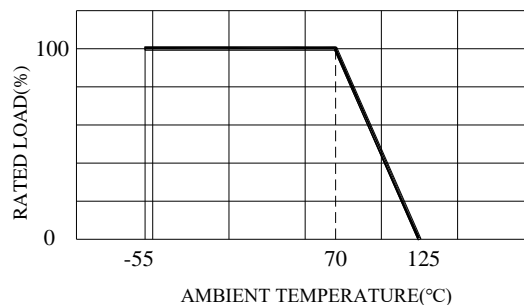

Figure 1. : Power Temperature Derating Curve

Note: **Resistors shall have a rated DC or AC(rms.) continuous operating voltage corresponding to the power rating, as calculated from the following formula

$$V = \sqrt{P \times R}$$

Where V : Rated voltage (V)

P : Rated power (W)

R : Nominal resistance (Ω)

the voltage so obtained exceeds the maximum operating voltage, this maximum voltage shall be the rated voltage.

Outline Drawing :

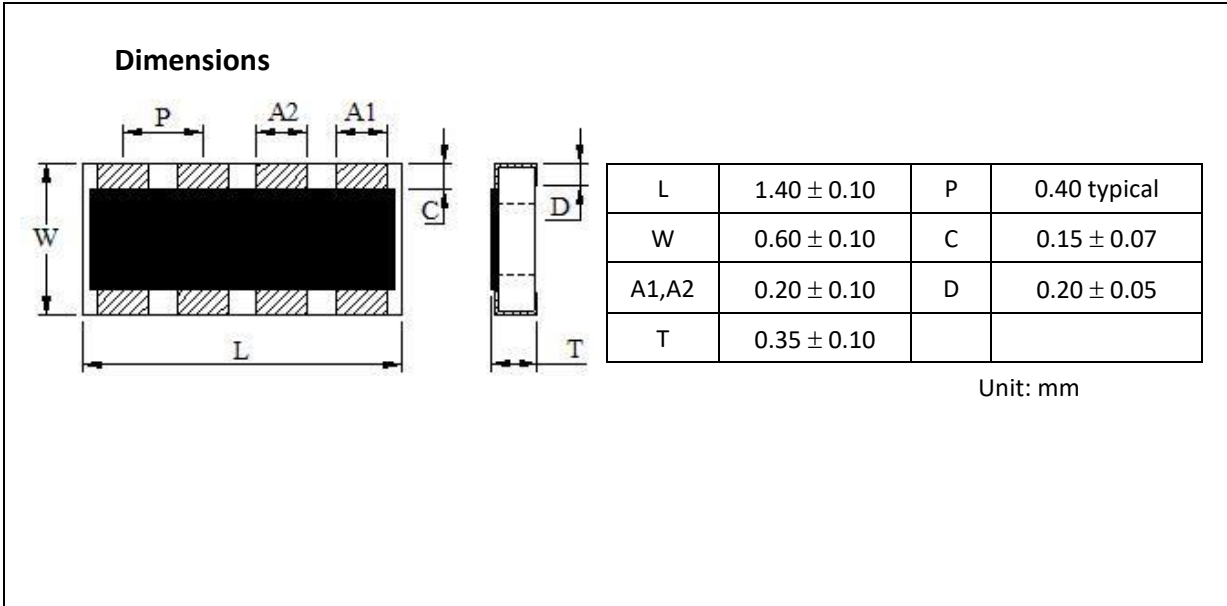

Schematics:

Resistor

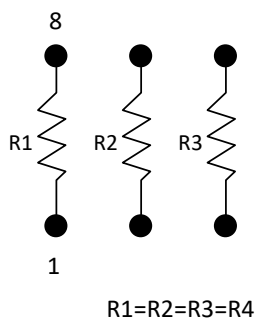

Jumper

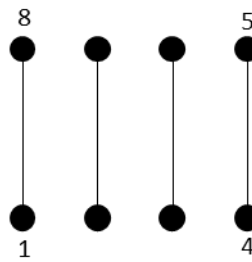

Type Designation :

RS064R - XXXX - X 2 NH
 (1) (2) (3) (4) (5)

Note :

- (1) Series No. 0.6mm x 1.4mm Size & 8 Pins 4 Resistors
- (2) Resistance value : 00R0=Jumper(0Ω) , 56R0 = 56Ω , 1001=1KΩ
- (3) Tolerance : F = ±1%, G = ±2%, J= ±5%, X= Jumper (Below 50 mΩ)
- (4) Outline type : 2 = Flat type
- (5) NH= Sn plating (Lead free / Halogen free)

Characteristics :

Electrical

Item	Specification and Requirement		Test Method (Refer to JIS C 5201)
	Resistor	Jumper	
Short Time Overload	$\Delta R: \pm (2\% + 0.1\Omega)$ Without damage by flashover, spark, arcing, burning or breakdown	Max. 50mΩ	(1) Applied voltage: 2.5 x rated voltage or 2 x maximum operating voltage which ever is less (2) Test time : 5 seconds
Insulation Resistance	Over 100 MΩ on Overcoat layer face up Over 1,000 MΩ on Substrate side face up		(1) Setup as figure 1 (2) Test voltage: 100 V _{DC} (3) Test time: 60 + 10 / -0 seconds
Voltage Proof	$R: \pm (2\% + 0.1\Omega)$ Without damage by flashover, spark, arcing, burning or breakdown	Max. 50mΩ	(1) Setup as figure 1 (2) Test voltage: 50 V _{AC} (rms.) (3) Test time: 60 +10 / -0 seconds

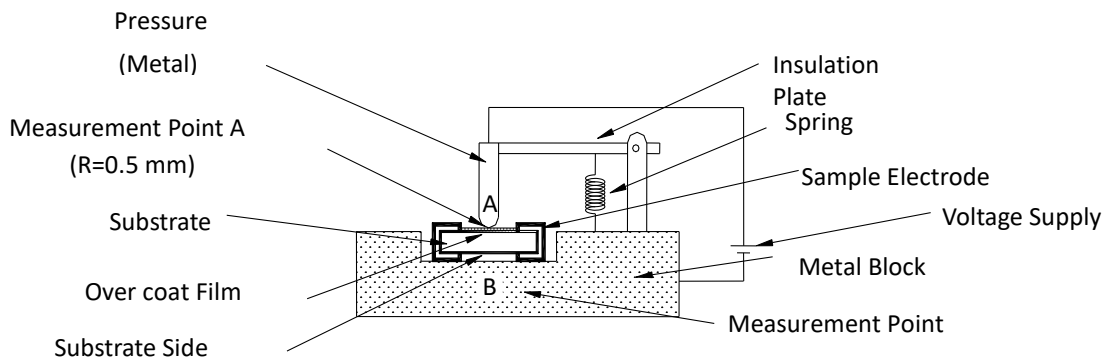

Figure 1 : Measurement Setup

Mechanical

Item	Specification and Requirement		Test Method (JIS 5201)
	Resistor	Jumper	
Solderability	The surface of terminal immersed shall be minimum of 95% covered with a new coating of solder		Solder bath: After immersing in flux, dip in $245 \pm 5^{\circ}\text{C}$ molten solder bath for 2 ± 0.5 seconds
Resistance to Solder Heat	$\Delta R: \pm(1\% + 0.05\Omega)$ Without distinct deformation in appearance	Max. $50\text{m}\Omega$	(1) Immersed at solder bath of $270 \pm 5^{\circ}\text{C}$ for 10 ± 1 seconds (2) Measuring resistance 1 hour after test
Vibration	$\Delta R: \pm(0.5\% + 0.05\Omega)$ Without mechanical damage such as break		(1) Vibration frequency: 10Hz to 55Hz in 60 seconds as a period (2) Vibration time: period cycled for 2 hours in each of 3 mutual perpendicular direction total. (3) Amplitude: 1.5mm
Shock	$\Delta R: \pm(0.25\% + 0.05\Omega)$ Without mechanical damage such as break		(1) Peak value: 490N (2) Duration of pulse: 11ms (3) 3 times in each positive and negative direction of 3 mutual perpendicular directions
Bending Test	$\Delta R: \pm(1\% + 0.05\Omega)$ Without mechanical damage such as break		Bending value : 3mm for 30 ± 1 seconds
Solvent Resistance	Without mechanical and distinct damage in appearance		(1) Solvent: Trichloroethane or Isopropyl alcohol (2) Immersed in solvent at room temperature for 90 seconds

Endurance

Item	Specification and Requirement		Test Method (Refer to JIS C 5201)
	Resistor	Jumper	
Thermal Shock	$\Delta R: \pm (1.0\% + 0.05\Omega)$ Without distinct damage in appearance	Max. 50m Ω	(1) Repeat 5 cycle as follow: (-55 \pm 3 $^{\circ}$ C,30minutes) \rightarrow (Room temperature, 2~3 minutes) \rightarrow (+125 \pm 2 $^{\circ}$ C,30minutes) \rightarrow (Room temperature, 2~3 minutes) (2) Measuring resistance 1 hour after test
Moisture with Load	$\Delta R: \pm (3.0\% + 0.1\Omega)$ Without distinct damage in appearance Marking should be legible	Max. 50m Ω	(1) Environment condition: 40 \pm 2 $^{\circ}$ C,90~95% RH (2) Applied Voltage: rated voltage (3) Test period: (1.5 hour ON) \rightarrow (0.5 hour OFF) cycled for total 1,000 + 48 / - 0 hours (4) Measuring resistance 1 hour after test
Load Life	$\Delta R: \pm (3.0\% + 0.1\Omega)$ Without distinct damage in appearance	Max. 100m Ω	(1) Test temperature: 70 \pm 2 $^{\circ}$ C (2) Applied Voltage: rated Voltage (3) Test period: (1.5 hour ON) \rightarrow (0.5 hour OFF) cycled for total 1,000 + 48 / - 0 hours (4) Measuring resistance 1 hour after test
Low Temperature Store	$\Delta R: \pm (3.0\% + 0.1\Omega)$ Without distinct damage in appearance	Max. 100m Ω	(1) Store temperature: -55 \pm 3 $^{\circ}$ C for total 1,000 + 48 / - 0 hours (2) Measuring resistance 1 hour after test
High Temperature Store	$\Delta R: \pm (3.0\% + 0.1\Omega)$ Without distinct damage in appearance	Max. 100m Ω	(1) Store temperature: +125 \pm 2 $^{\circ}$ C for total 1,000 + 48 / - 0 hours (2) Measuring resistance 1 hour after test

Recommend Land Pattern Dimensions :

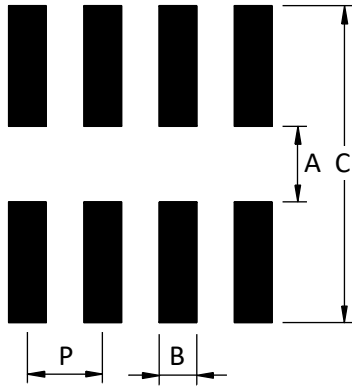

A	0.3
B	0.2
C	0.9
P	0.4

Unit : mm

TAPE PACKAGING DIMENSIONS:

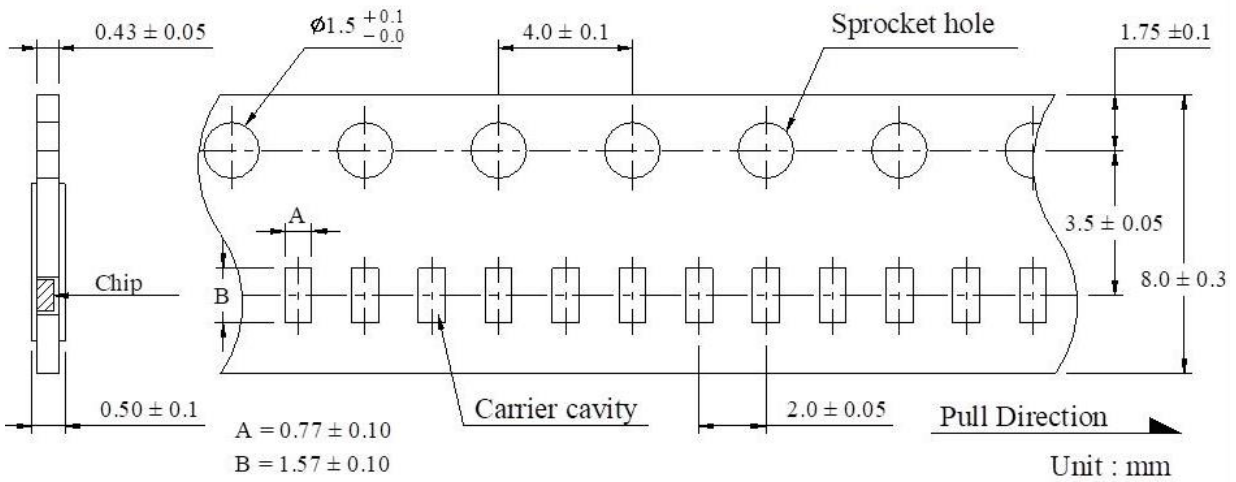

REEL DIMENSIONS:

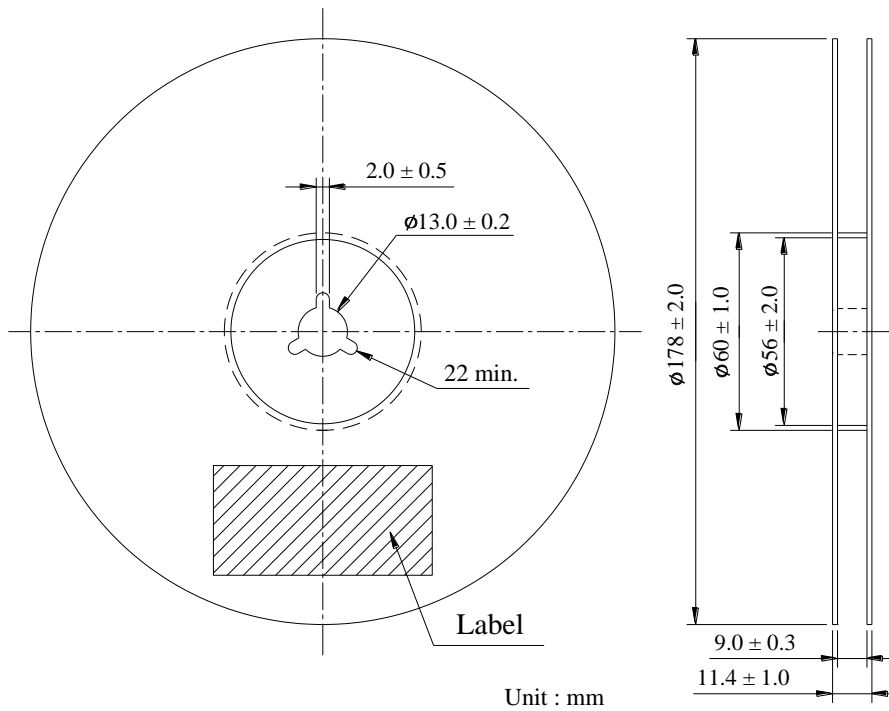

Numbers of Taping : 10,000 pieces/reel

The following items shall be marked on the reel.

- (1) Type designation.
- (2) Quantity
- (3) Manufacturing date code
- (4) Manufacturer's name

Peel force of top cover tape

The peel speed shall be about 300 mm/min. The peel force of top cover tape shall be between 0.1 to 0.7 N.

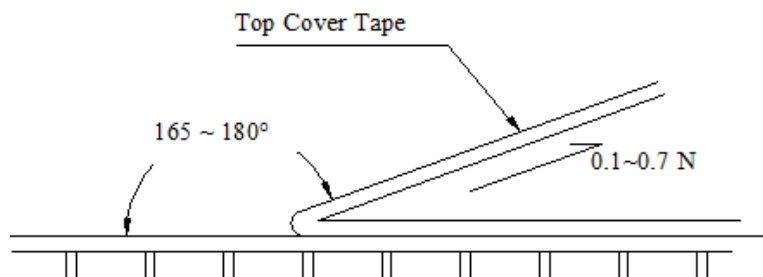

Care Note :

Care note for storage

- (1) Chip resistor shall be stored in a room where temperature and humidity must be controlled.
(temperature 5 to 35°C, humidity 45 to 85% RH) However, a humidity keep it low, as it is possible.
- (2) Chip resistor shall be stored as direct sunshine doesn't hit on it.
- (3) Chip resistor shall be stored with no moisture, dust, a material that will make solderability inferior, and a harmful gas (Hydrogen chloride, sulfurous acid gas, and Hydrogen sulfide)

Care note for operating and handling

- (1) It is necessary to protect the edge and protection coat of resistors from mechanical stress.
- (2) Handle with care when printing circuit board (PCB) is divided or fixed on support body, because bending of printing circuit board (PCB) mounting will make mechanical stress for resistors.
- (3) Resistors shall be used with in rated range shown in specification. Especially, if voltage more than specified value will be loaded to resistor, there is a case it will make damage for machine because of temperature rise depending on generating of heat, and increase resistance value or breaks.
- (4) In case that resistor is loaded a rated voltage, it is necessary to confirms temperature of a resistor and to reduce a load power according to load reduction curve, because a temperature rise of a resistor depends on influence of heat from mounting density and neighboring element.
- (5) Observe Limiting element voltage and maximum overload voltage specified in each specification.
- (6) If there is possibility that a large voltage (pulse voltage, shock voltage) charge to resistor, it is necessary that operating condition shall be set up before use.