

VSPA6918SY-0M10J, Shunt Sensor (Lead / Halogen Free)

Features / Applications :

- High power rating is up to 36W
- Low inductance (< 5 nH)
- Low thermal EMF (< 3 $\mu\text{V}/^\circ\text{C}$)
- Welding construction; Excellent long-term stability
- RoHS compliant & AEC-Q200 qualified
- Automotive applications & Current sensing for BMS
- Sn plating assists with PCB mounting and corrosion protection

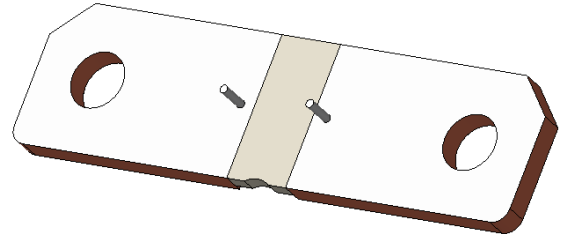

Electrical Specifications :

Characteristics	Feature
Power Rating*	36 W
Resistance Value	100 $\mu\Omega$
Temperature Coefficient of Resistance	$\pm 100 \text{ ppm}/^\circ\text{C}$
Operation Temperature Range	$-65^\circ\text{C} \sim +170^\circ\text{C}$
Resistance Tolerance	$\pm 5\%$ (J)
Maximum Working Voltage (V)	$(P \cdot R)^{1/2}$

*Note :

For sensors operated at terminal temperature in excess of 140°C , the maximum load shall be derated in accordance with the following curve.

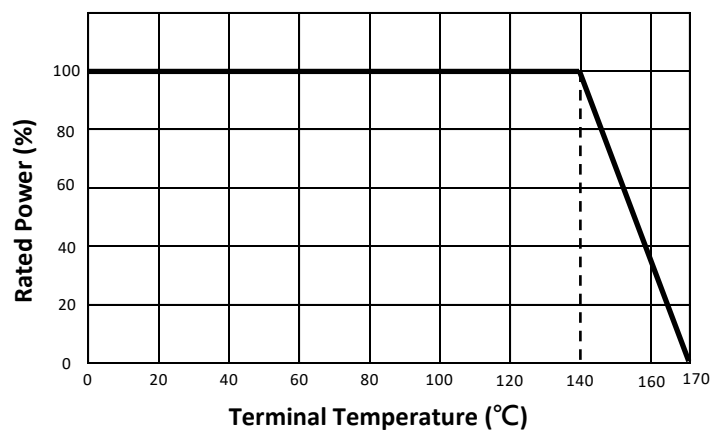

Figure 1. : Power derating curve at terminal temperature

Outline Drawing :

Unit: mm

Dimension

A Side

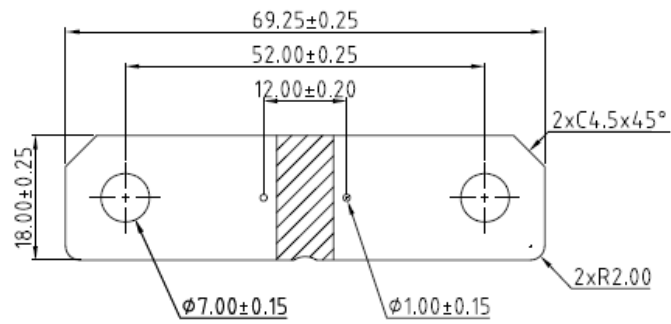

D Side

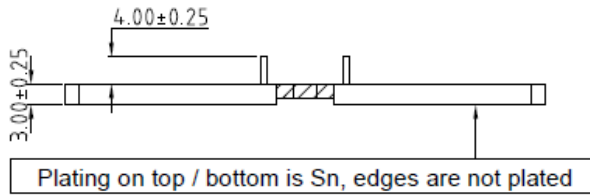

B Side

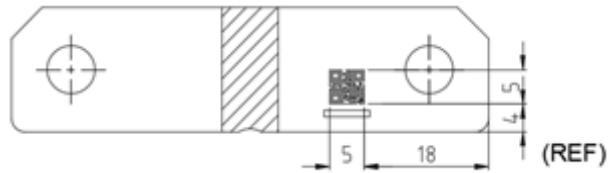

Type Designation :

V S P A 6 9 1 8 S Y - 0 M 1 0 J
(1) (2) (3) (4) - (5) (6)

Note :

- (1) Series No.
- (2) Size
- (3) Terminal type : S = Short terminal
- (4) Power Rating : Y = 36W
- (5) Resistance value : 0M10 = 100 $\mu\Omega$
- (6) Tolerance : J = $\pm 5\%$

Characteristics :

Electrical

Item	Specification and Requirement	Test Method
Temperature Coefficient (TCR)	As follow specification	JIS-C-5201 +25°C/ +125°C.
Short Time Overload	$\Delta R: \pm 0.5\%$ Without damage by flashover, spark, arcing, burning or breakdown	JIS-C-5201-1 4.13 5 x rated power for 5 seconds.
ESD	$\Delta R: \pm 1\%$	AEC-Q200-002 Human body, 8KV.

Mechanical

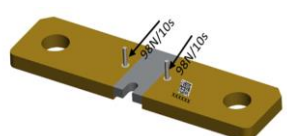
Item	Specification and Requirement	Test Method
Solderability	The surface of terminal immersed shall be minimum of 95% covered with a new coating of solder	J-STD-002 245 ± 5°C for 5 ± 0.5 seconds.
Resistance to Solder Heat	$\Delta R: \pm 0.5\%$	MIL-STD-202 Method 210 260 ± 5°C for 10 ± 1 seconds.
Vibration	$\Delta R: \pm 0.5\%$ Without distinct damage in appearance	MIL-STD-202 Method 204 5G's for 20 minutes, 12 cycles each of 3 orientations. Test from 10-2000Hz.
Mechanical Shock	$\Delta R: \pm 0.5\%$ Without distinct damage in appearance	MIL-STD-202 Method 213 100G's peak value, 6ms, Half-sine waveform, 12.3ft/sec.
Pin Strength	Without damage and break from bottom of pin.	 <p>Test height <1.6mm from bottom of pin.</p>

Endurance

Item	Specification and Requirement	Test Method
Temperature Cycling	$\Delta R: \pm 0.5\%$	JESD22 Method JA-104 1000 cycles, (-55°C~150°C) 30 min maximum dwell time at each temperature.
Biased Humidity	$\Delta R: \pm 0.5\%$	MIL-STD-202 Method 103 1000 hours, 85°C/85%R.H, applied for 10% rated power.
Operational Life	$\Delta R: \pm 1.0\%$	MIL-STD-202 Method 108 100% Rate power for 1,000 hours at terminal temperature 140°C.
High Temperature Store	$\Delta R: \pm 1.0\%$	MIL-STD-202 Method 108 170°C for 1,000 hours.

Note : Measurement at 24±4 hours after test conclusion for all reliability tests-parts.

Packaging :

Tray packaging dimensions :

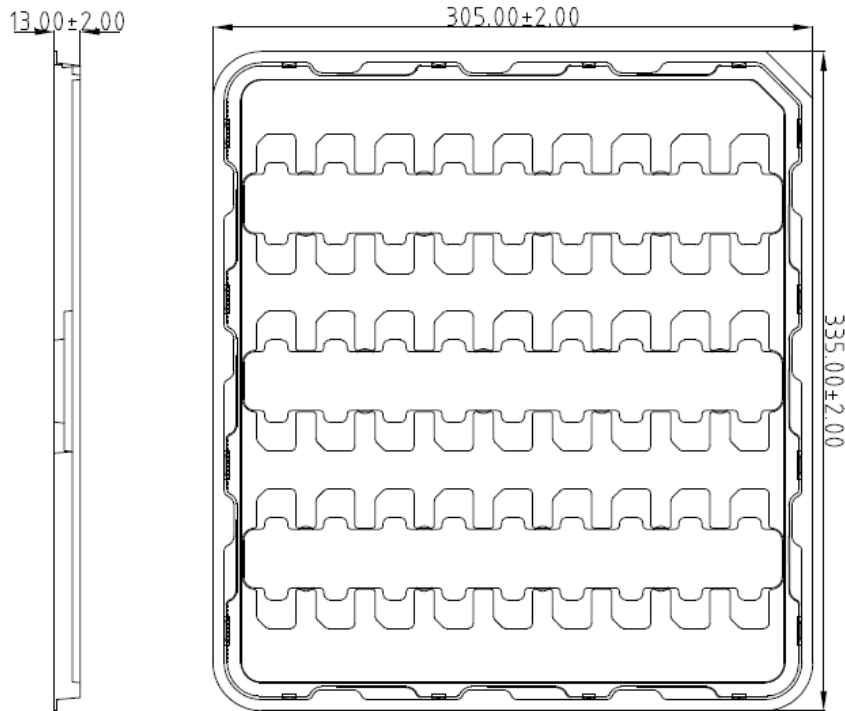

Label Marking :

The following items shall be marked on tray

- (1) Description
- (2) Quantity
- (3) Part No.
- (4) Tapping No.

Quantity: 27 Pcs / Tray
 135 Pcs / Carton

Care Note :

Care note for storage

- (1) Shunt sensor shall be stored in a environment where temperature and humidity must be controlled (temperature 5 to 35°C, humidity < 60% RH) . However, the humidity should be maintained as low as possible.
- (2) Shunt sensor shall not be stored under direct sunlight.
- (3) Shunt sensor shall be stored in condition without moisture, dust, any material defect solderability, or hazardous gas (i.e. Chloridation hydrogen, sulfurous acid gas, and sulfuration hydrogen)
- (4) The sensor can be stored for at least one year under the condition mentioned above.

Care note for operating and handling

- (1) Protect the edge and coating of the sensors from mechanical stress.
- (2) Avoid bending of printing circuit board (PCB) when cutting and fixing it on support body to reduce mechanical stress on sensors.
- (3) Sensor should be used within the condition of specification.
Note: When a voltage higher than specified value is loaded to the sensor, this may damage the sensor material due to temperature rise.
- (4) The loaded voltage should consult terminal temperature of the sensor according to the derating curve.
- (5) When applying a high current exceeding suggested specification (pulse current, shock current) to the sensor, it is necessary to re-evaluate the operating condition before using it in the system.